

Hardwired DRO Installation on a Bench Lathe

The LittleMachineShop.com [kit #6387](#) includes everything you would need to add DRO to your HiTorque bench lathe.

If you want to retrofit a Bluetooth DRO system to hardwiring, you only need to replace the read heads with heads wired to 9-pin connectors ([part # 6467](#)), the DRO display unit ([part #6464](#)) and a display mounting arm ([part # 6469](#)).

Your current scales will work with the hardwired version.

Safety Considerations

Always use common sense when using power tools and working with electrically powered equipment. To safely install this DRO kit, the lathe should be powered off and unplugged from a power source.

Digital Position Readout fits both sizes of LittleMachineShop.com bench lathes, 8.5x16 and 8.5x20. The cross slide scale is the correct length for both sizes. The longer carriage scale is the correct length for 8.5x20 bench lathes, including LittleMachineShop.com HiTorque models 3540, 3595, and 7500. For 8.5x16 lathes, the scale simply extends farther to the right than the carriage can travel.

Note: Because the scales are manufactured for use worldwide, they are made to metric dimensions. From this point forward in this document, dimensions shown are in millimeters.

Be Sure You Have Everything

The kit includes the following items:

- Read Heads with 9-pin adapter (qty 2)
Note, the machine screws are often loosely packages in the read head envelopes. They will be needed, 2 for each read head.
- Scales (qty 2)
- DRO Display (qty 1)
- Display mounting bracket - 2 parts (qty 1)

Read Head Brackets

- Y-Axis back bracket (qty 1)
- Y-Axis front bracket (qty 1)
- X-Axis flat bracket (qty 1)
- X-Axis L-bracket (qty 1)
-

Fasteners

- M3x6 pan head screws (qty 6)
- M3x10 pan head screws (qty 2)
- M3x14 pan head screws (qty 2)
- M4x14 pan head screws (qty 2)
- M3x34.5 threaded studs (qty 2)
- M3 hex nuts (qty 4)

Don't worry if you get a few extra items. They may be for a different version of this kit.

In addition, you'll need the following tools, which are not included with the DRO kit:

- 2.5 mm or #39 drill bit*
- 3.3 mm or #30 drill bit*
- 5.5 mm or 7/32" drill bit*
- M3x0.5 thread-cutting tap*
- M4x0.7 thread-cutting tap*
- PH 1 Phillips screwdriver
- 5.5 mm end wrench or small adjustable wrench

*These tools are available as a kit (PN 5820) from LittleMachineShop.com

Preparing for installation

You need to remove a few things before you install the DRO components.

1. Remove the blocking socket head cap screw between the ways and remove the tailstock.
2. Remove the compound rest by removing the two socket head cap screws on either side of it.
3. Remove the rear splash guard.
4. Unbolt the lathe from the bench or stand so you can place it on its back.

Installing the cross slide scale and reader

Follow these steps to install the DRO scale and reader on the cross slide.

1. Mark four hole locations on the right (tailstock) side of the cross slide as shown in the drawing below.

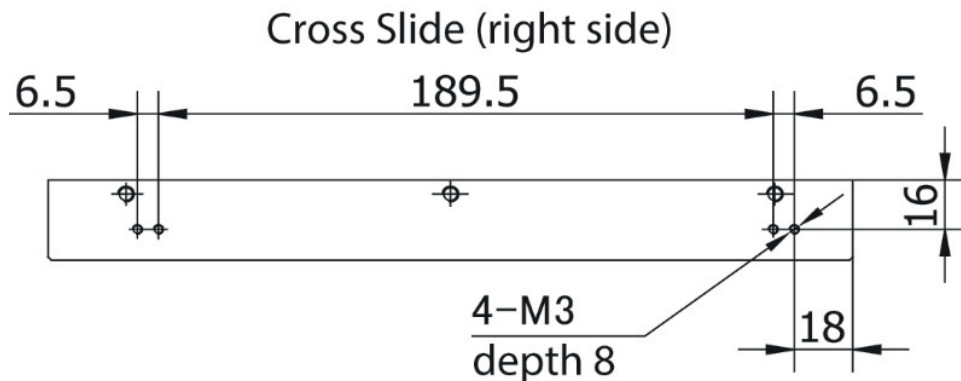

2. Drill and tap the four holes M3. Use a 2.5 mm or #39tap drill and an M3x0.5 metric tap.

3. Mark two hole locations on the right (tailstock) side of the saddle as shown in the drawing below. Note that the 7 mm dimension is measured from the top sliding surface of the saddle.

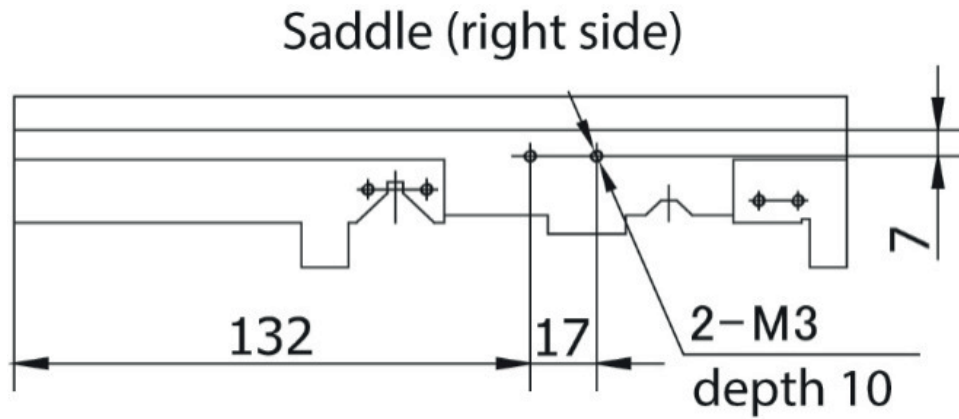

4. Drill and tap the two holes M3. Use a 2.5 mm or #39 tap drill and an M3x0.5 metric tap.
5. Preassemble a cross slide scale bracket on each end of the scale as shown in the photo below.



6. Attach the scale to the cross slide using four M3x6 Phillips head screws.

7. Attach the reader to the saddle with two studs and 4 M3 nuts as shown in the drawing below.

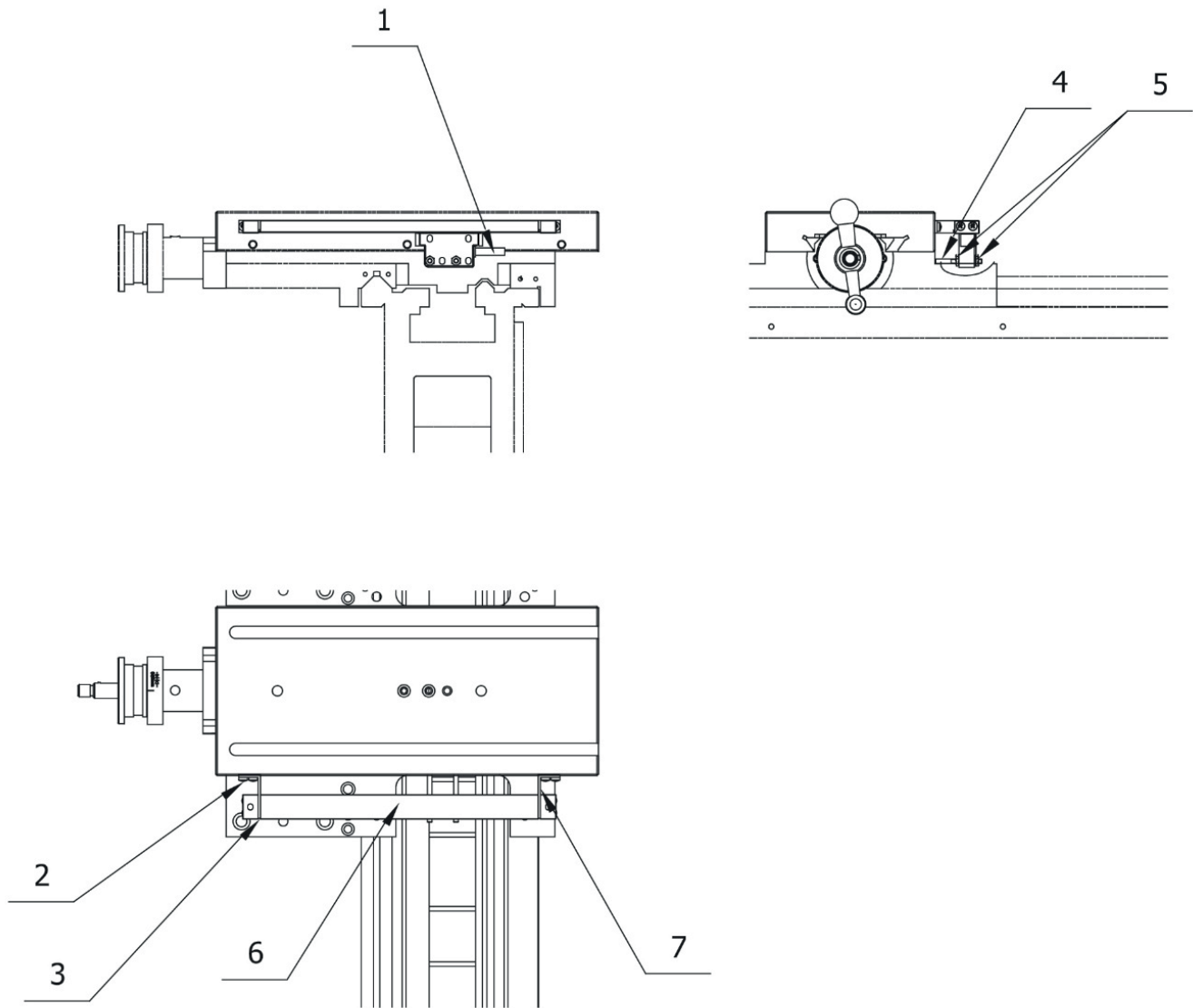

Cross slide DRO mounting

Item	Qty	Item	Item	Qty	Item
1	1	Read Head	5	4	M3 Hex Nuts
2	4	M3x6 Phillips head screws	6	1	Magnetic scale (Y-axis)
3	1	Cross slide scale bracket, front	7	1	Cross slide scale bracket, rear
4	2	Threaded Stud			

Installing the carriage scale

Follow these steps to install the carriage scale.

1. Mark three hole locations on the bed way as shown in the drawing below.

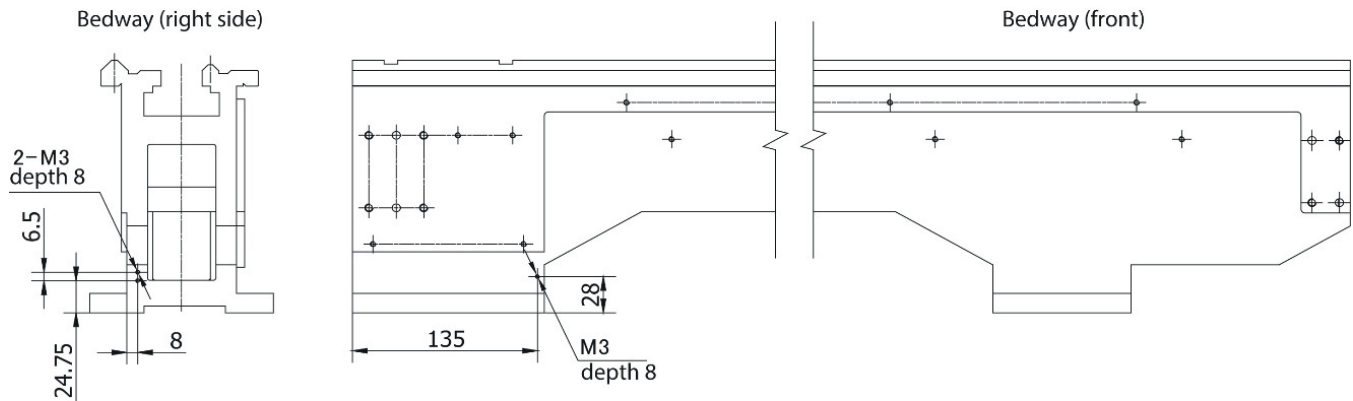

2. Drill and tap the three holes M3. Use a 2.5 mm or #39 tap drill and an M3x0.5 metric tap.
3. Install the scale mounting bracket to the right foot of the bed ways using 2 M3x6 Philips head screws.
4. Install the long scale to the bed way and scale mounting bracket using 2 M3x10 Philips head screws.

Installing the carriage reader

1. Mark one hole location on the bottom of the apron as shown in the drawing below. (You will use one of the existing cover mounting holes.) Drill right through the cover and into the casting. Drill the hole with a 3.3 mm or #30 drill but don't tap it yet.

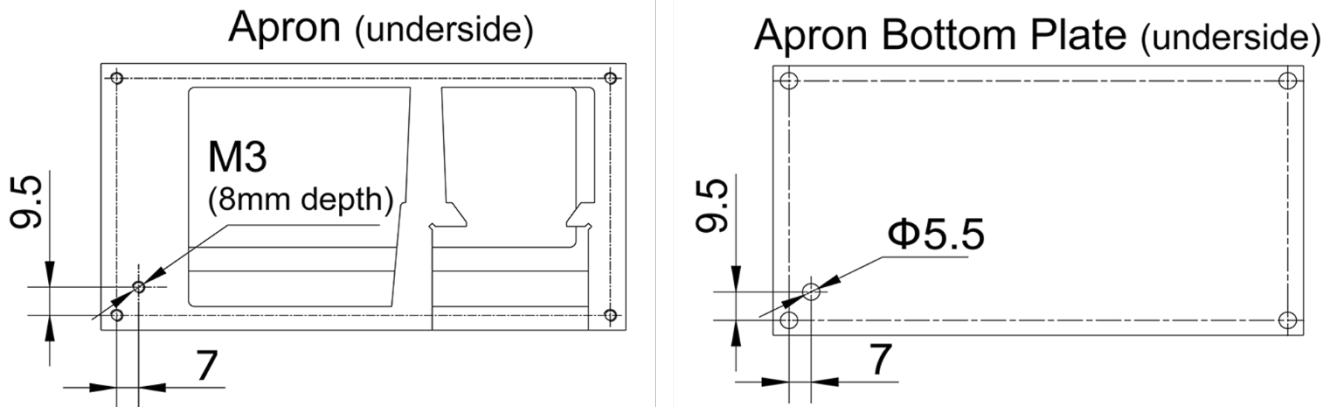

2. Remove the cover from the bottom of the apron. Enlarge the hole you drilled in the cover with a 5.5 mm or 7/32" drill.
3. Tap the new hole in the casting M4. Use an M4x0.7 metric tap.
4. Replace the cover on the bottom of the apron with 3 screws in the other corners.
5. Install the bracket with 2 M4x14 Phillips head screws reader on the bottom of the apron as shown in the following drawing.
6. Install the read head using two M3x14 Phillips head screws.

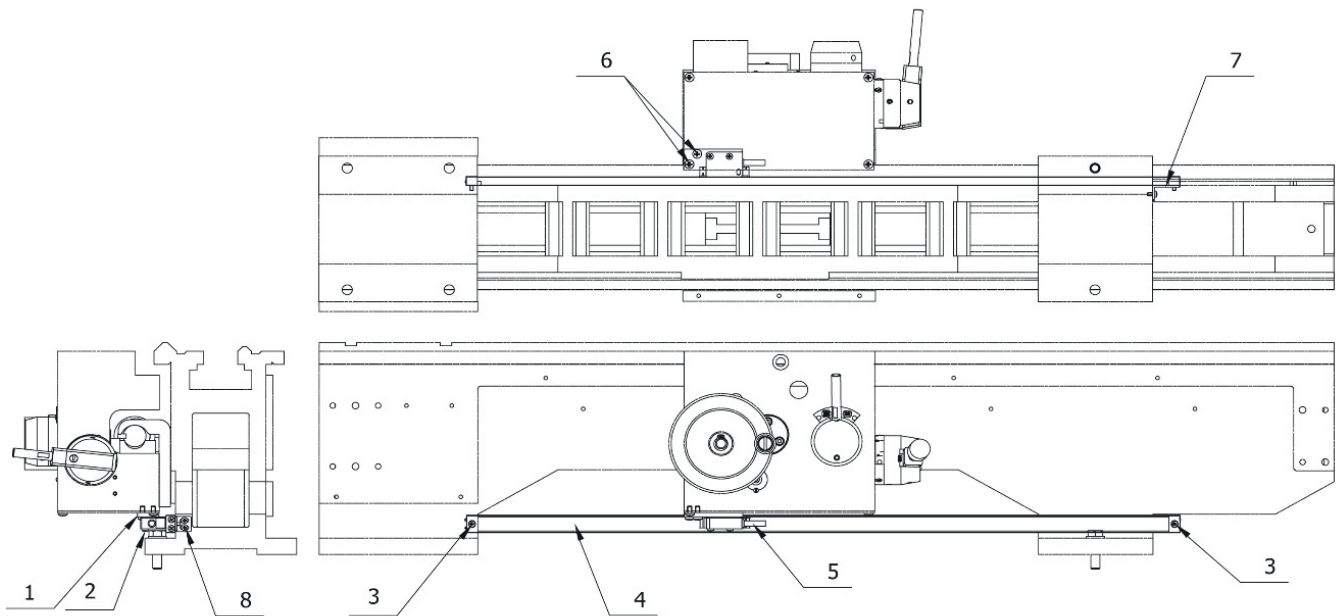

Bed Way & Carriage mounting

Item	Qty	Item	Item	Qty	Item
1	1	Carriage reader bracket	5	1	Read Head
2	2	M3x14 Phillips head screws	6	2	M4x14 Phillips head screw
3	2	M3x10 Phillips head screws	7	1	Bed way scale bracket
4	1	Magnetic scale (X-axis)	8	2	M3x6 Phillips head screw

Reassembling the lathe

7. Replace the compound rest with the two socket head cap screws.
8. Replace the tailstock and blocking socket head cap screw.
9. Replace the rear splash guard.
10. Bolt the lathe to the bench or stand.

Adjusting the read heads

Adjust the DRO read heads so that the chip plows touch the stainless strip, but the reader head is clear of it.

The read head must be straight and centered on the scale.



Done!

That's it, the DRO is ready to go. Fire up the display and go to work.