

## Bluetooth DRO Installation for Bench Mills

The LittleMachineShop.com [Bench Mill 3-Axis DRO kit #6388](#) includes everything you need to add a DRO to your HiTorque Bench Mill.

If you want to retrofit a Bluetooth DRO system to hardwiring, you only need to replace the read heads with heads wired to 9-pin connectors ([part # 6467](#)), the DRO display unit ([part #6464](#)) and a display mounting arm ([part # 6469](#)).

Your current scales will work with the hardwired version.

### *Safety Considerations*

Always use common sense when using power tools and working with electrically powered equipment. To safely install this DRO kit, the mill should be powered off and unplugged from a power source.

### *Project Summary*

The installation of the DRO system involves mounting magnetic scales on the three axes (X, Y & Z) then mounting the read heads on brackets that are positioned so that the read heads glide along the scales sending positioning information to the display unit.

The X and Y-axis read heads are mounted on brackets that are affixed to the saddle. The Z-axis read head is mounted on a bracket attached to the mill's headstock. The magnetic scales are installed on the back of the table (X-axis), the mill base (Y-axis) and on the column with mounting through the cover (Z-axis).

The mounting arm for the DRO display is mounted to the right side of the column in holes that must be drilled and tapped as indicated later in these instructions.

Note: Because the scales are manufactured for use worldwide, they are made to metric dimensions. From this point forward in this document, dimensions shown are in millimeters.

## Be Sure You Have Everything

The kit includes the following items:

- Read Heads with 9-pin adapter (qty 3)  
*Note, the machine screws are often loosely packages in the read head envelopes. They will be needed, 2 for each read head.*
- Magnetic scale for X axis
- Magnetic scale for Z axis
- Magnetic scale for Y axis

### Mounting Brackets & Spacers

- Reader mounting bracket - L-shaped (qty 2)
- 17x24x10 mm Z-axis reader mounting spacer (qty 1)
- 13x24x10 mm X-axis reader mounting spacer (qty 1)
- 24x10x8 mm Y-axis reader mounting spacer (qty 1)
- Y-axis scale threaded support bolt (qty 2)

### Mounting fasteners

- M3x10 pan head machine screw (qty 6)
- M3x14 pan head machine screw (qty 4)
- M3x25 pan head machine screw (qty 2)
- M4x20 socket head cap screw (qty 2)
- M4x25 socket head cap screw (qty 2)
- Z-axis scale mounting washers (qty 2)
- M5 nut (qty 2)

Don't worry if you get a few extra items. They may be for a different version of this kit.

In addition, you'll need the following tools, which are not included with the DRO kit:

- 2.5 mm or #39 drill bit\*
- 3.3 mm or #30 drill bit\*
- 4.2 mm or #19 drill bit
- 10 mm or 0.375" drill bit
- M3x0.5 thread-cutting tap\*
- M4x0.7 thread-cutting tap\*
- M5x0.8 thread-cutting tap
- 2.5 mm hex key wrench
- PH 1 Phillips screwdriver

\*These tools are available as a kit (PN 5820) from [LittleMachineShop.com](http://LittleMachineShop.com)

## Install the X-Axis Scale and Reader

Chris' Tip: These instructions tell how to remove the table so the mounting holes for the X-axis scale may be drilled true. If you feel you can drill the two M2 holes on the back of the table without removing it, you can skip to [{insert link}](#).

To remove the table:

1. Remove the retainer that attaches the chip guard bellows to the back of the mill table. Two screws hold the retainer in place; remove the screws and the retainer and set them aside.
2. Remove the two socket head cap screws that secure the Y-axis bearing retainer to the front of the saddle.
3. Unscrew the Y-axis screw from the machine. The bearing retainer and screw will come out of the front of the machine. When it is about 1/3 of the way out, remove the socket head cap screw and washer from the back end of the screw.
4. Loosen the Y-axis gib and slide the mill table and saddle forward off the machine.

(Caution! The table and saddle on a bench mill weighs up to 60 pounds, so you might want to have a friend help you with this step.)

Follow these steps to install the scale and reader for the X-axis.

1. Clean the back side of the mill table and the saddle to remove all chips and oil.
2. On the back side of the mill table, mark two hole locations as shown below.

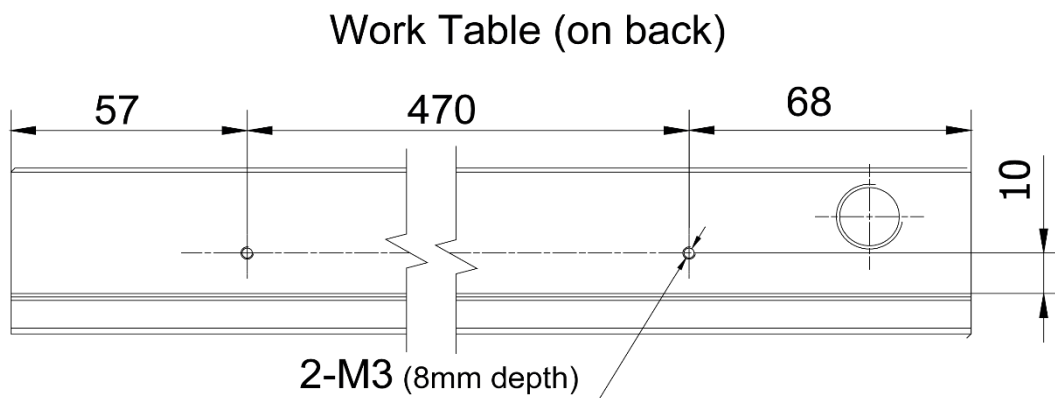

3. Drill and tap the two holes M3 to a depth of 8 mm (0.3 in). Use a 2.5 mm or #39 tap drill and an M3x0.5 metric tap.

- On the back of the saddle, mark two hole locations as shown below.

### Saddle (on back)

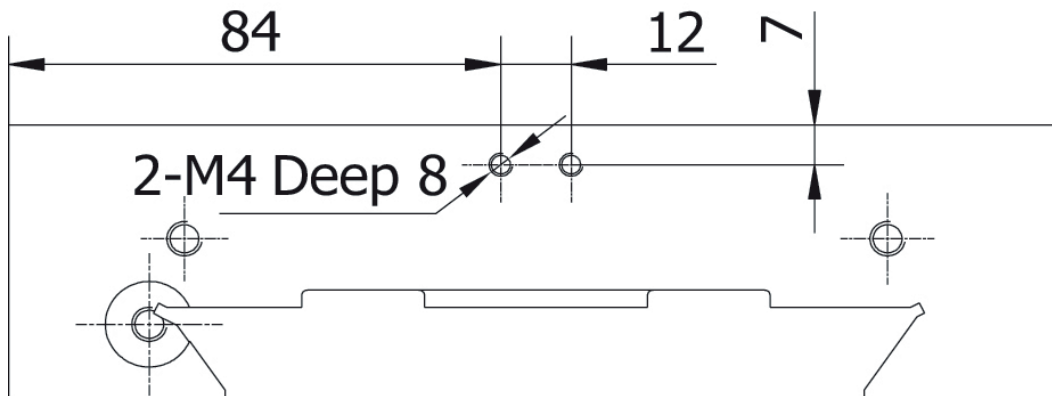

- Drill and tap the two holes M4 to a depth of 8 mm (0.3 in). Use a 3.3 mm or #30 tap drill and an M4x0.7 metric tap.
- Use two M3x10 pan head screws to attach the magnetic scale to the back of the mill table.
- Reassemble the mill table and adjust the X-axis gib.
- Install the X-axis reader with a 13 mm reader mounting spacer and reader mounting bracket as shown in the drawing below.

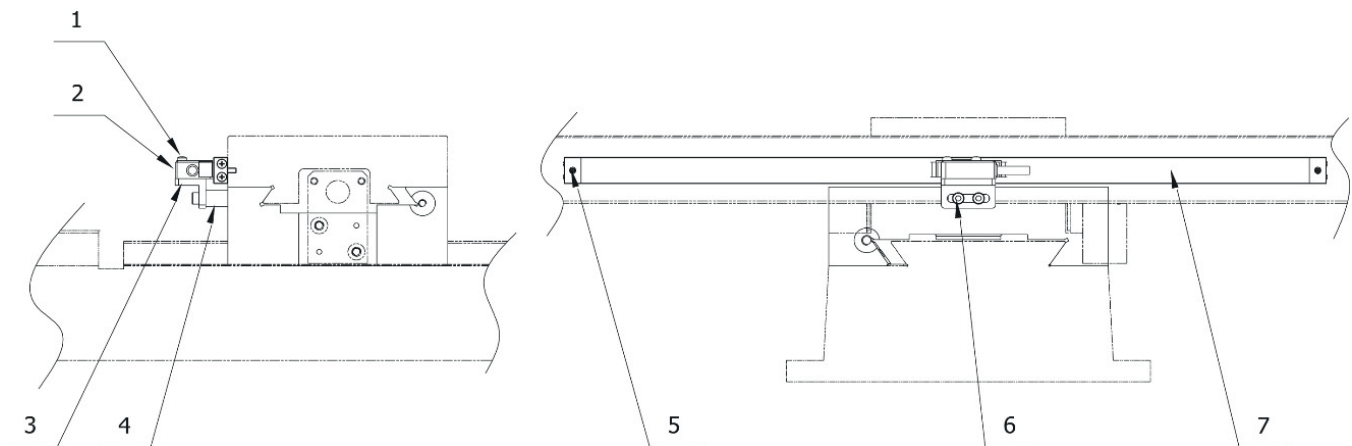

Item	Qty	Item	Item	Qty	Item
1	2	M3x14 pan head machine screw	5	2	M3x10 pan head machine screw
2	1	Read Head	6	2	M4x20 socket head cap screw
3	1	Reader mounting bracket	7	1	Scale 460 mm
4	1	13 mm reader mounting spacer			

## Install the Y-Axis Scale and Reader

Follow these steps to install the scale and reader for the Y-axis.

1. On the left side of the saddle, mark two hole locations as shown below.

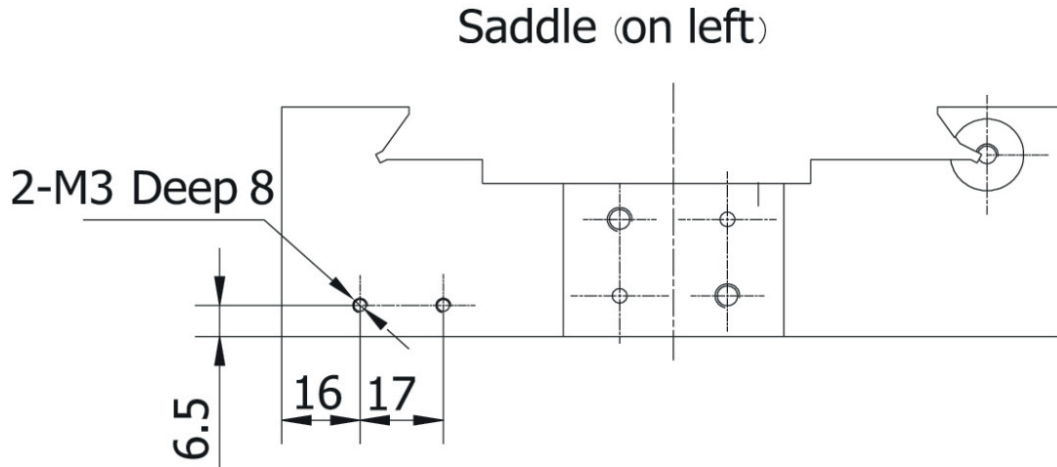

2. Drill and tap the two holes M3 to a depth of 8 mm (0.3 in). Use a 2.5 mm or #39 tap drill and an M3x0.5 metric tap.
3. On the left side of the machine base, mark two hole locations as shown below.

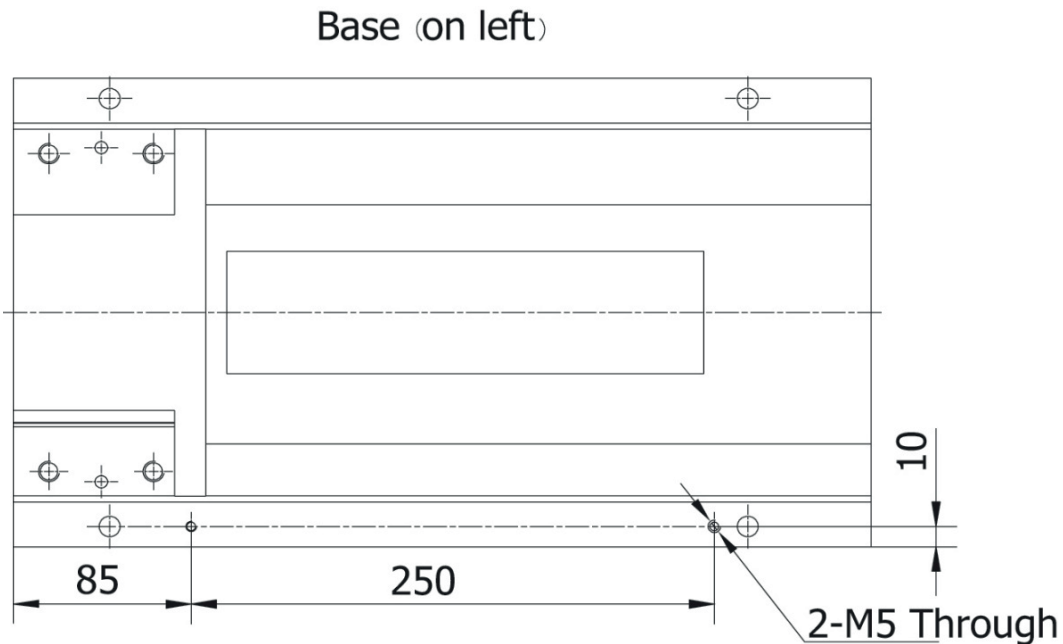

4. Drill and tap the two holes M5 to a depth of at least 13 mm (0.5 in). Through holes are ok. Use a 4.2 mm or #19 tap drill and an M5x0.8 metric tap.
5. Install an M5 nut on each standoff post and screw the standoff posts into the M5 holes in the base.

6. Install the Y-axis scale onto the standoff posts using two M3x10 pan head machine screws.
7. Install the Y-axis reader using a 10 mm reader mounting spacer, and M3x10 pan head machine screws as shown in the drawing below.

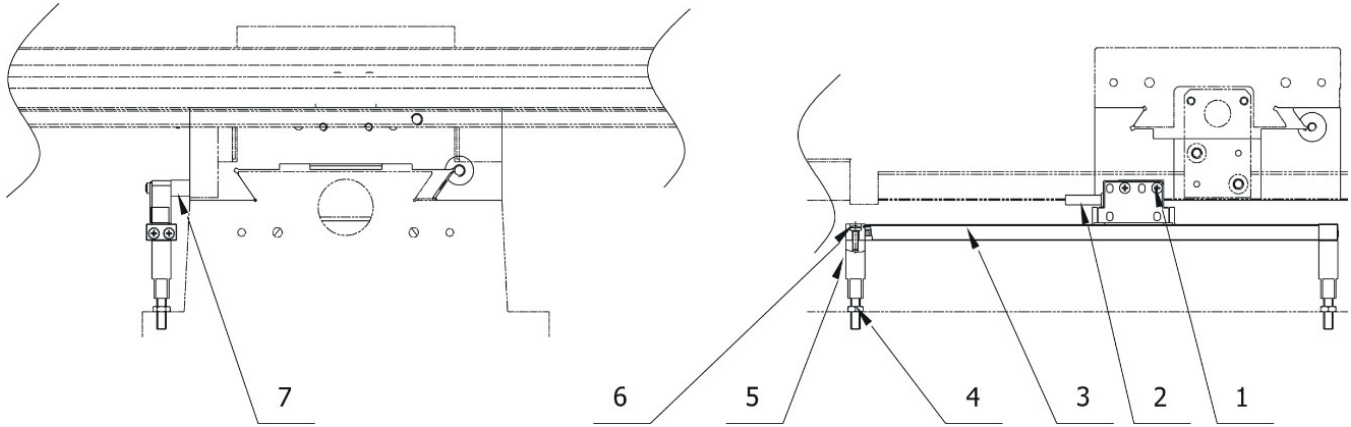

Item	Qty	Item	Item	Qty	Item
1	2	M3x25 pan head machine screw	5	2	Mounting standoff post
2	1	Read Head	6	2	M3x10 pan head machine screw
3	1	Scale 240 mm	7	1	10 mm reader mounting spacer
4	2	M5 nut			

## Install the Z-Axis Scale and Reader

Follow these steps to install the scale and reader for the Z-axis.

1. Remove the four socket head cap screws that secure the sheet metal column housing to the column.
2. Pull the cover back, but be aware that it is still connected by some wires.
3. On the left side of the column, mark two hole locations as shown below. Don't drill these holes yet.

### Column (on left)

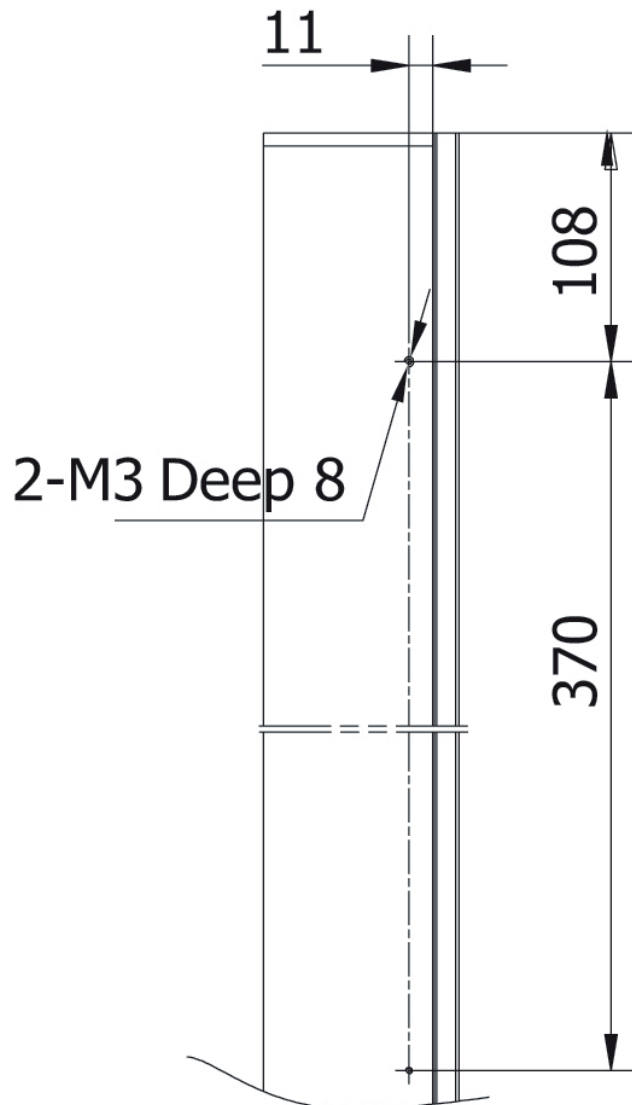

4. On the left side of the column housing, mark the two hole locations as shown below. These are clearance holes for the Z-axis scale mountings, so be sure they will align with the two holes in the column. Notice that these holes are large enough (10 mm) to provide clearance for slight misalignment.

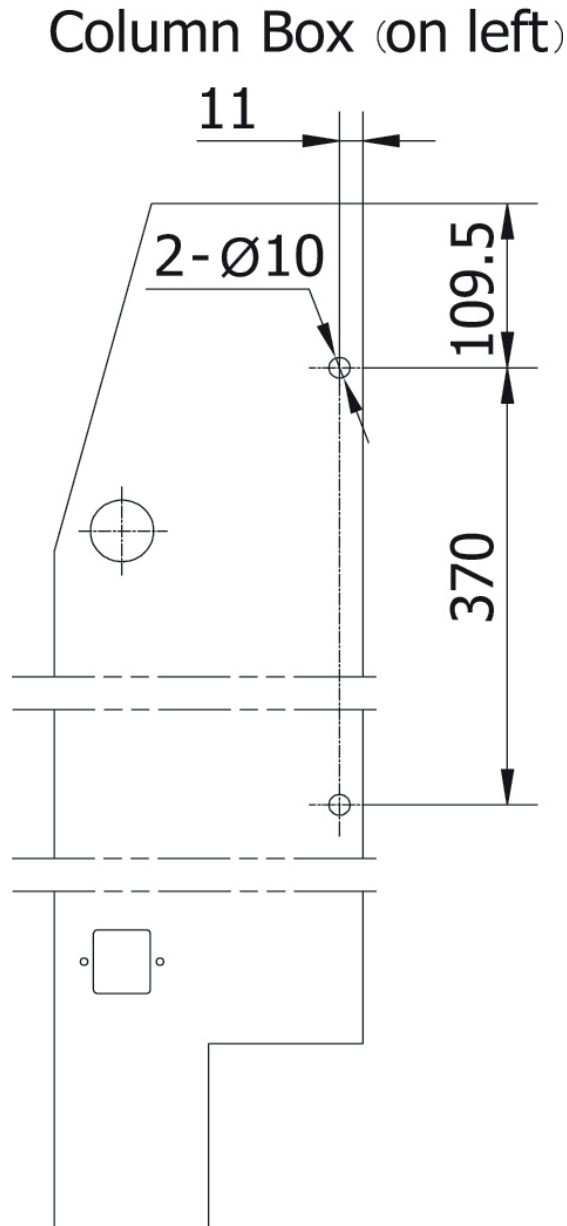

5. Drill and tap the two M3 holes in the column to a depth of 8 mm (0.3 in). Use a 2.5 mm or #39 tap drill and an M3x0.5 metric tap.
6. Drill the two clearance holes in the column housing 10 mm (0.375") through.



7. On the right side of the head assembly, mark two hole locations as shown below.

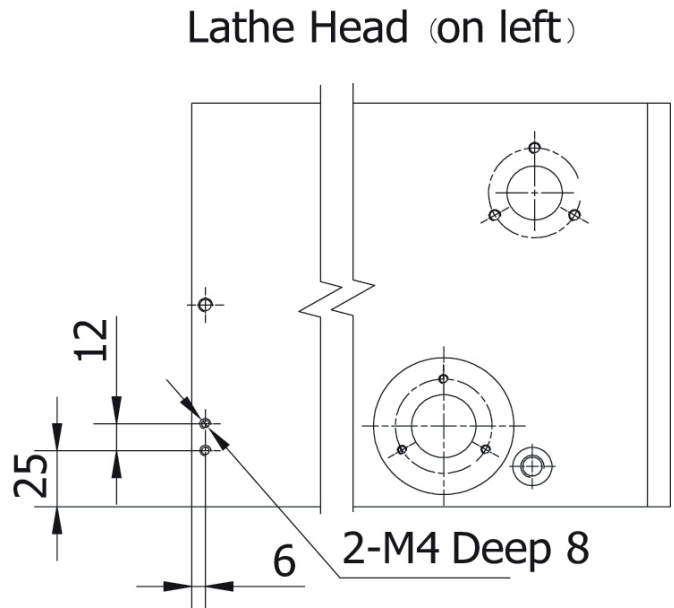

8. Drill and tap the two holes M4 to a depth of 8 mm (0.3 in). Use a 3.3 mm or #30 tap drill and an M4x0.7 metric tap.
9. Reinstall the sheet metal column housing to the column.
10. Install the Z-axis scale using two 4 mm round scale mounting spacers and M3x10 Phillips machine screws.

1. Install the Y-axis read head using a 17 mm reader mounting spacer, a reader mounting bracket and two M4x25 socket head cap screws as shown in the drawing below.

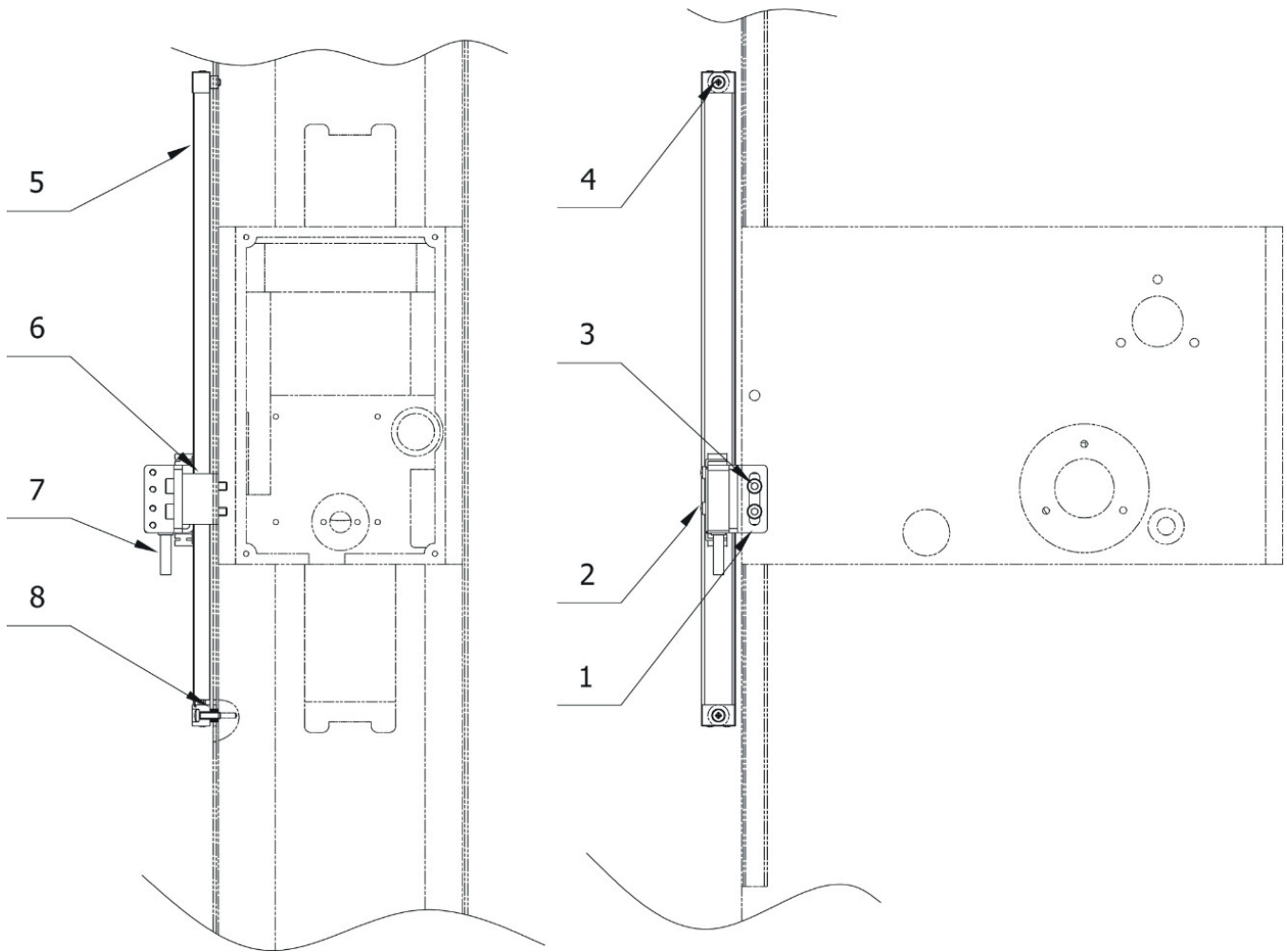

Item	Qty	Item	Item	Qty	Item
1	1	Reader mounting bracket	5	1	Scale 360 mm
2	2	M3x14 pan head machine screw	6	1	17 mm reader mounting spacer
3	2	M4x25 socket head cap screw	7	1	Reader
4	2	M3x10 pan head machine screw	8	2	4 mm round scale mounting spacer

## *Adjusting the Read Heads*

Adjust the DRO read heads so that the chip plows touch the stainless strip, but the reader head is clear of it.

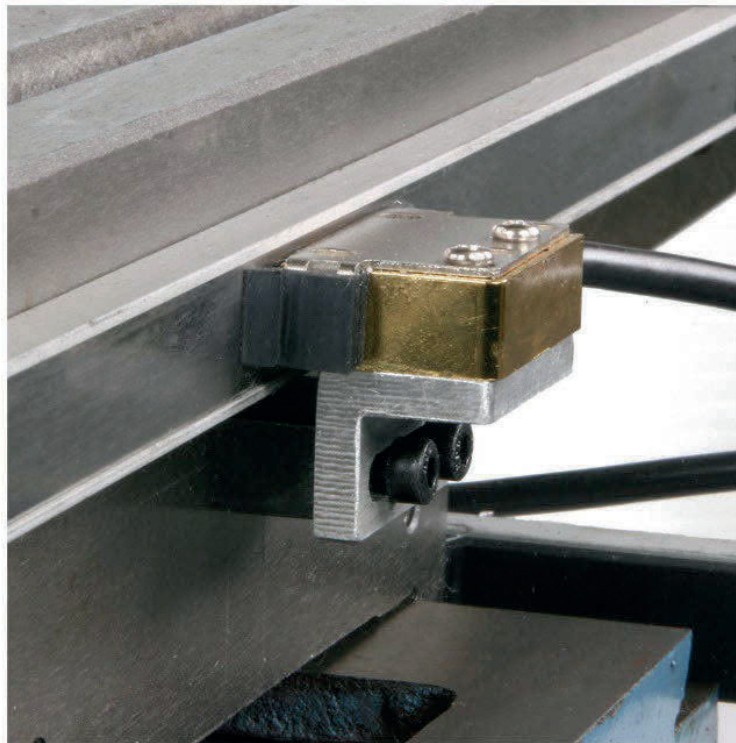

*Done!*

That's it, the DRO is ready to go. Fire up the Android tablet and go to work.