

BC20-2V/BC20-3V

# MULTI-FUNCTIONAL DIGITAL READOUTS

## Operation Manual

Dear Users:

Thank you for purchasing BC20-V series digital readouts. The digital readout is applicable for the machines such as milling, lathe, boring, grinding and EDM, etc.. Read all the instructions in the manual carefully before used and strictly follow them. Keep the manual for future references.

When using the manual:

This manual includes:

**BC20-2V** : the readout used for 2 axis milling machine and grinding machine and lathe machine.

**BC20-3V** : the readout used for 3 axis milling machine and lathe machine and EDM machine.

Safety attention:

To prevent electric shock or fire, moisture or directly sprayed cooling liquid must be avoid. In case of any smoke or peculiar smell from the digital readout, please unplug the power plug immediately, otherwise, fire or electric shock may be caused. In such a case, do not try to repair it, please contact us or our distributors.

Digital readout is a precise measuring device used with an optical Linear Scale. When it is in use, if the connection between the Linear Scale and the digital readout is broken or damaged externally, incorrect measuring values may be resulted. Therefore, the user should be careful.

Do not try to repair or modify the digital readout, otherwise, failure, fault or injury may occur. In case of any abnormal condition, please contact us or our distributors.

If the optical Linear Scale used with the digital readout is damaged, do not use a Linear Scale of other brand. Because the performance, specification and connection of the products of different and can not be connected without the instruction of specialized technical personnel, otherwise, trouble will be caused to the digital readout.

### BC20-3V Readout Panel and Keyboard

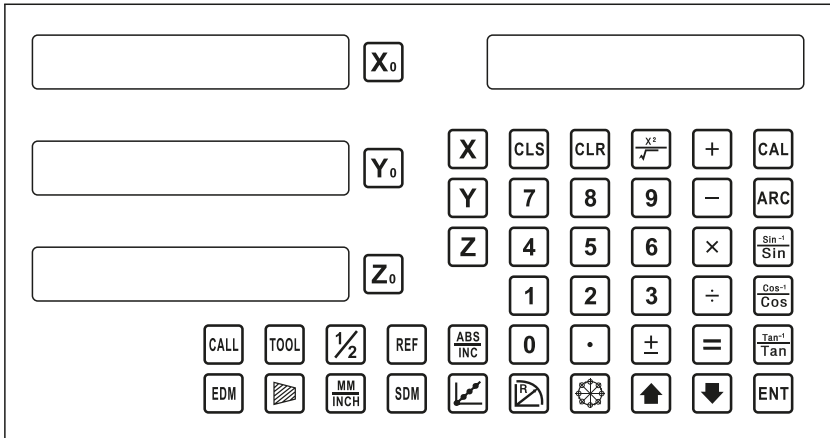



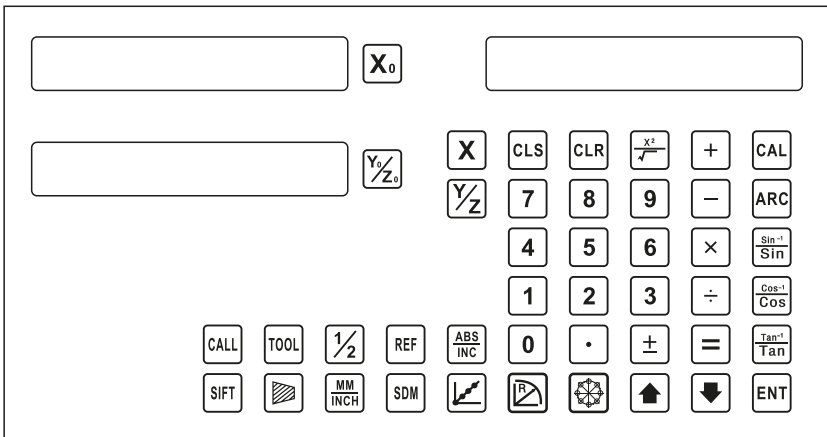





















### BC20-2V Readout Panel and Keyboard



## Contents

---











### Caption of the Keyboard of BC20-2V/BC20-3V

-    \_\_\_\_\_ Keys for Axis selection
-       
     \_\_\_\_\_ Entry keys for digits
-      \_\_\_\_\_ Operation Key (in Calculation function key)
-  \_\_\_\_\_ Calculation function key  
(in Calculation function key)
-  \_\_\_\_\_ Input (calculation result)  
Canceling key (in Calculation function key)
-  \_\_\_\_\_ Key for "Inverting"  
Trigonometric Functions  
(in Calculation function key)
-  \_\_\_\_\_ Square root calculating key  
(in Calculation function key)
-  \_\_\_\_\_ Entry Keys for decimal point
-  \_\_\_\_\_ Entry key plus or minus symbol
-  \_\_\_\_\_ Key for entering data

## Contents

---

### Caption of the Keyboard of BC20-2V/BC20-3V

-  ————— Key for cleaning the displayed value to zero
-  ————— Function key for getting one half (press X, Y, or Z, then press this key)  
Key for radius ( for Lathe)
-  ————— Key for the conversion the meter System/British system
-  ————— Function key for Sleep
-  ————— Function Key for 200 sdm
-  ————— R angular ARC Function Key (ARC Function key)
-  ————— Function key for circle equally Dividing (PCD Function key); when select 3 axis Lathe, function key for Y+Z->Z ( only for LATHE 3)
-  ————— Function key for drilling holes along an oblique line
-  ————— Angular surface processing function key; In calculation function as sine trigonometric function key
-  ————— Progressive inner chamber processing function key; In calculation function as cosine trigonometric function key

## Contents

---

### Caption of the Keyboard of BC20-2V/BC20-3V



————— Tool compensation function key; In calculation function as tangent trigonometric function key



————— Key for the conversion of relative /absolute display



————— Key for the selection of upper / lower term or plane procession



————— Key for taper measure function



————— Key for calling 200 tool storeroom



————— Key for input 200 tool storeroom



————— Function key for machine output ( EDM )



————— Function key for data filtration

## Contents

1. General description	
1.1 BC20-2V for MILL .....	2
1.2 BC20-2V for Lathe .....	3
1.3 BC20-2V for Grind .....	4
1.4 BC20-3V for MILL .....	5
1.5 BC20-3V for Lathe .....	6
1.6 BC20-3V for EDM .....	7
2. Parameters settings	
2.1 Encode type setting .....	9
2.2 Resolution setting .....	9
2.3 Direction setting .....	9
2.4 Compensation Type (Linear or Non-Linear) setting.....	10
3. Basic Functions	
3.1 Reset.....	12
3.2 MM / INCH Mode.....	12
3.3 Enter dimensions.....	12
3.4 1 / 2 function.....	13
3.5 ABS / INC Mode .....	14
3.6 Clear 200 sets Sdm datum .....	14
3.7 NON-VOLATILE MEMORY.....	14
3.8 Sleeping Mode.....	14
3.9 Ref datum memory function.....	15
3.9.1 Find Ref (Find the ref mark position) .....	16
3.9.2 Recall the work datum zero (FD ORG).....	17
3.10 Linear Compensation.....	18
3.11 Non-linear Error Compensation.....	18
3.12 200 sets SubDatum function.....	20

## Contents

---

4. Special Functions	
4.1 Linear Drilling.....	26
4.2 PCD Function.....	27
4.3 R Function.....	28
4.3.1 SMOOTH R Function.....	29
4.3.2 SIMPLE R Function.....	33
4.4 Chambering.....	36
4.5 Tool Compensation Function.....	37
4.6 Machining of oblique plane .....	38
4.7 Calculator .....	40
4.8 Machining Function of the Grinding Machine	
4.8.1 Digital Filter.....	41
4.9 Machining Function of Lathe .....	42
4.9.1 200 sets TOOL Libs.....	42
4.9.2 Taper Function .....	44
4.9.3 R / D Function .....	44
4.9.4 Y + Z Function for 3 axes Lathe .....	44
4.10 Machining Function of EDM .....	45
4.10.1 description .....	45
4.10.2 procedure .....	46
4.10.3 PCD function for EDM .....	48
4.10.4 Linear drilling for EDM.....	48
5. Appendix .....	51
5.1 Specifications of Digital Readout .....	51
5.2 Installation Diagram .....	51
5.3 Troubleshooting .....	52



# 1. General Description

# 1. General Description

## 1. General Description:

Set the power switch to ON, the DRO enters to the self-check and init state. The resolution will be display on the X, Y, Z LED window, and the type of the DRO will be display on the left window. Mill 2 for 2 axes Milling Machine, Mill 3 for 3 axes Milling machine, GRIND 2 for 2 axes Grind, Lathe 2 for 2 axes Lathe and Lathe 3 for 3 axes Lathe etc.

BC20-2V and 3V readout can be easily set to MILL, Grind, Lathe, EDM etc. Set the power switch to On, press the key  $\frac{MM}{INCH}$  six times until the right window displays the type, then press the key  $\uparrow$  and  $\downarrow$  to select the correct type.

### 1.1 BC20-2V for MILL

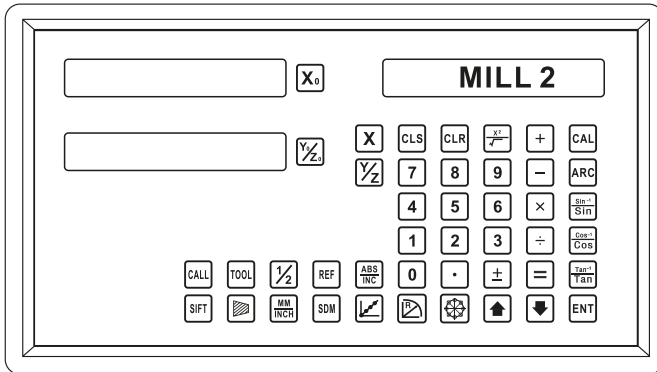

Applicable to: milling machine, Boring machine, etc:

Basic Function:

- 1)Reset; 2)MM/INCH Mode; 3)Enter dimension; 4) 1 / 2 Function;
- 5)ABS/INC Mode; 6)Clear 200 sets Sdm datum; 7)Non-Volatile Memory;
- 8)Sleeping Mode; 9)Ref Datum Memory Function;
- 10) Linear Compensation; 11) Non-Linear Error Compensation;
- 12) 200 sets sub datum Function; 13) Parameters setting

Special Function:

- 1) Linear Drilling; 2) PCD Function; 3) R Function;
- 4) Chambering; 5) Tool Compensation Function;
- 6) Machining of oblique plane; 7) Calculator;

Special Key:



1.2 BC20-2V for Lathe

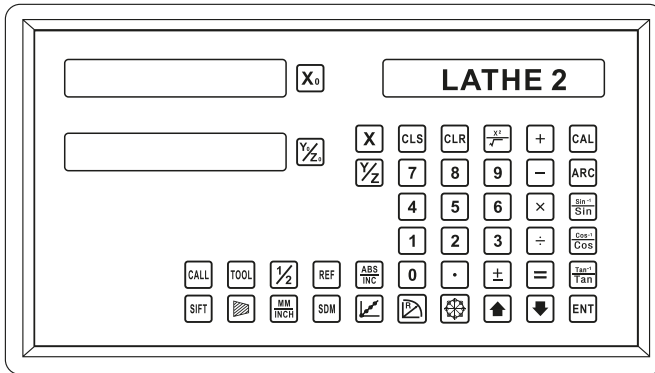

Applicable to: 2 axes Lathe:

Basic Function:

- 1)Reset; 2)MM/INCH Mode; 3)Enter dimension;
- 4)ABS/INC Mode; 5)Clear 200 sets Sdm datum; 6)Non-Volatile Memory;
- 7)Sleeping Mode; 8)Ref Datum Memory Function;
- 9) Linear Compensation; 10) Non-Linear Error Compensation;
- 11) 200 sets sub datum Function; 12) Parameters setting

Special Function:

- 1) 200 set TOOL Libs;
- 2) R / D Function;
- 3) Taper Function;

Special Key:



1.3 BC20-2V for GRIND

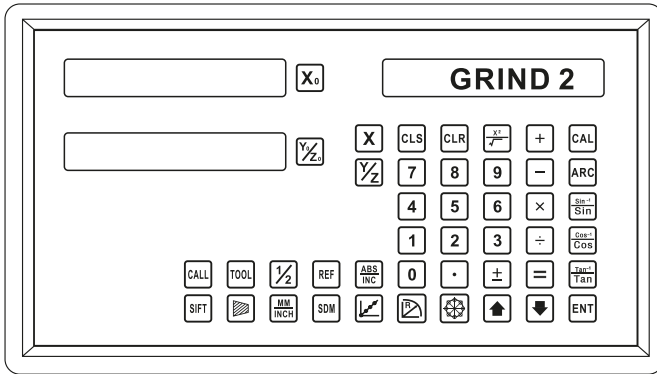

Applicable to: 2 axes Grinding Machine:

Basic Function:

- 1)Reset; 2)MM/INCH Mode; 3)Enter dimension; 4) 1 / 2 Function;
- 5)ABS/INC Mode; 6)Clear 200 sets Sdm datum; 7)Non-Volatile Memory;
- 8)Sleeping Mode; 9)Ref Datum Memory Function;
- 10) Linear Compensation; 11) Non-Linear Error Compensation;
- 12) 200 sets sub datum Function; 13) Parameters setting

Special Function:

- 1) Display Filter;

Special Key:



## 1.4 BC20-3V for MILL

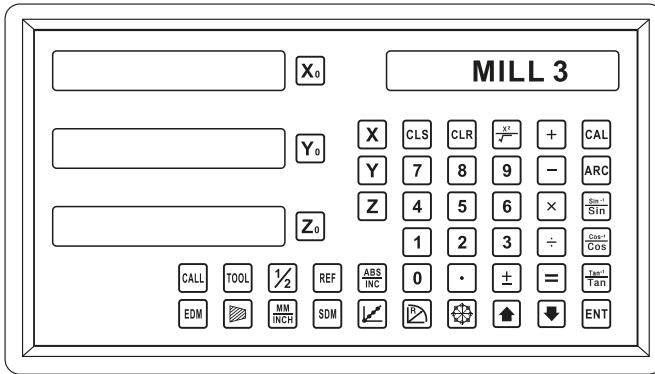

Applicable to: 3 axes milling machine, Boring machine, etc

Basic Function:

- 1)Reset;
- 2)MM/INCH Mode;
- 3)Enter dimension;
- 4) 1 / 2 Function;
- 5)ABS/INC Mode;
- 6)Clear 200 sets Sdm datum;
- 7)Non-Volatile Memory;
- 8)Sleeping Mode;
- 9)Ref Datum Memory Function;
- 10) Linear Compensation;
- 11) Non-Linear Error Compensation;
- 12) 200 sets sub datum Function;
- 13) Parameters setting

Special Function:

- 1) Linear Drilling;
- 2) PCD Function;
- 3) R Function;
- 4) Chamfering;
- 5) Tool Compensation Function;
- 6) Machining of oblique plane;
- 7) Calculator;

Special Key:



## 1.5 BC20-3V for Lathe

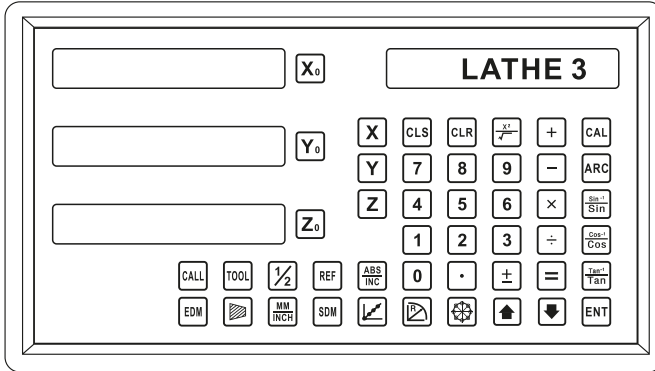

Applicable to: 3 axes Lathe:

Basic Function:

- 1)Reset; 2)MM/INCH Mode; 3)Enter dimension;
- 4)ABS/INC Mode; 5)Clear 200 sets Sdm datum; 6)Non-Volatile Memory;
- 7)Sleeping Mode; 8)Ref Datum Memory Function;
- 9) Linear Compensation; 10) Non-Linear Error Compensation;
- 11) 200 sets sub datum Function; 12) Parameters setting

Special Function:

- 1) 200 set TOOL Libs; 2) R / D Function; 3) Taper Function;
- 4) Y + Z Function;

Special Key:



## 1.3 BC20-3V for EDM

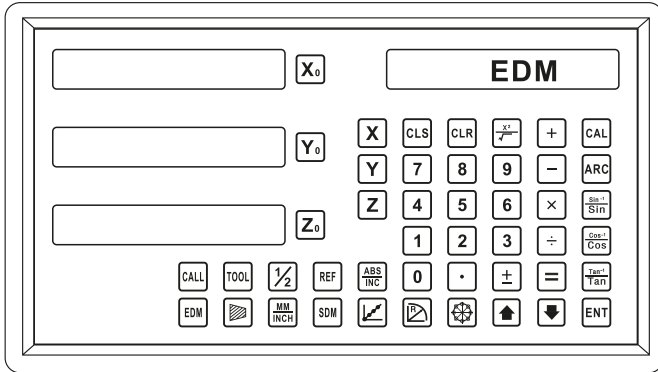

Applicable to: 3 axes EDM

Basic Function:

- 1)Reset; 2)MM/INCH Mode; 3)Enter dimension; 4) 1 / 2 Function;
- 5)ABS/INC Mode; 6)Clear 200 sets Sdm datum; 7)Non-Volatile Memory;
- 8)Sleeping Mode; 9)Ref Datum Memory Function;
- 10) Linear Compensation; 11) Non-Linear Error Compensation;
- 12) 200 sets sub datum Function; 13) Parameters setting

Special Function:

- 1) Linear Drilling; 2) PCD Function; 3) EDM Function;

Special Key:



## 2. Parameters Setting



## 2. Parameters setting

### 2. Parameters setting

Set the power switch to ON, the DRO enters to the self-check and init state. The resolution will be display on the X, Y, Z LED window, and the type of the DRO will be display on the left window. Mill 2 for 2 axes Milling Machine, Mill 3 for 3 axes Milling machine, GRIND 2 for 2 axes Grind, Lathe 2 for 2 axes Lathe, etc.

In the course of self-check, press the key  to access the System settings. In the System settings, the following system item will be set.

- 1) encode type, 2) Resolution, 3) direction,
- 4) compensation Type (Linear or Un-Linear) settings.

**Step 1:** Select the encode type: LINER encode or Rotary encode.

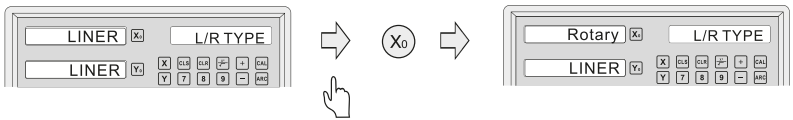

Press the key  $X_0$  to toggle the X axis encode type between LINER encode or Rotary encode. Press the key  $Y_0$  for the Y axis and press the key  $Z_0$  for the Z axis..

Press  to enter the Step 2.

**Step 2:** Set the resolution for encode

When selecting the LINER encode, the resolution will be set as follow:

There are 7 types of Resolution: 0.1 $\mu$ m;0.2 $\mu$ m;0.5 $\mu$ m;1 $\mu$ m;2 $\mu$ m;2.5 $\mu$ m;5 $\mu$ m;10 $\mu$ m

Press  $X_0$  for the X axis, the key  $Y_0$  for the Y axis and the key  $Z_0$  for the Z axis.

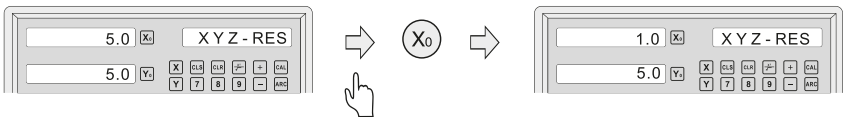

When selecting the Rotary encode, the resolution will be set as follow: input the rotary parameters.

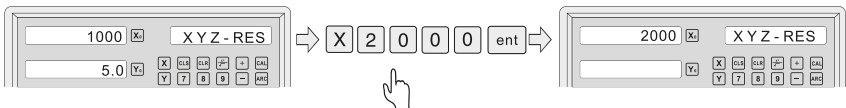

Press  to enter the Step 3.

## 2. Parameters setting

**Step 3:** Set the direction.

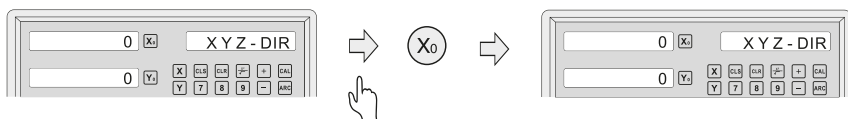

Press  $X_0$  for the X axis, the key  $Y_0$  for the Y axis and the key  $Z_0$  for the Z axis.

Press  $\downarrow$  to enter the Step 3.

**Step 4:** Set the compensation Type ( Linear or Non-Linear).

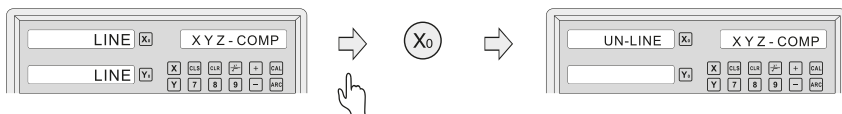

LINE: the Linear compensation; ( Ref to Linear compensation settings )

UN-LINE: the Non-Linear compensation (Ref to Non-Linear Error compensation)

Press  $X_0$  for the X axis, the key  $Y_0$  for the Y axis and the key  $Z_0$  for the Z axis.

Press  $\square$  to quit the Parameters setting.

## 3. Basic Functions

### 3. Basic Functions

#### 3. Basic Functions:

##### 3.1 Reset:

Function: Reset the current position for that axis by pressing the key  $X_0$  or  $Y_0$  or  $Z_0$ .

Example: to Reset the current X position.

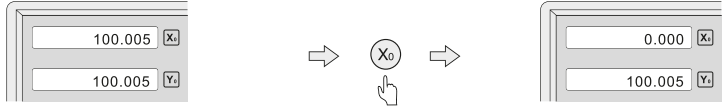

##### 3.2 MM/INCH MODE

Function: Toggle the display unit between inch and metric by pressing  $\frac{\text{mm}}{\text{inch}}$ .

Example 1: currently in inch display MODE, to toggle to metric display MODE.

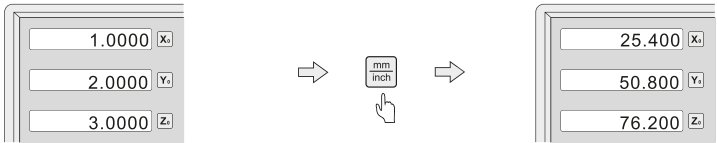

Example2: currently in metric display MODE, to toggle to inch display MODE.

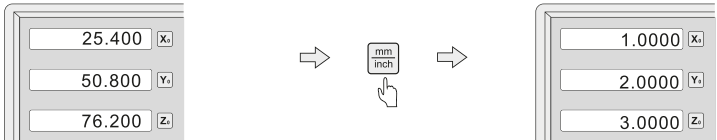

##### 3.3 Enter Dimensions

Function: set the current position for that axis to an entered Dimension.

Example: To set the current X-Axis position to 16.8mm.

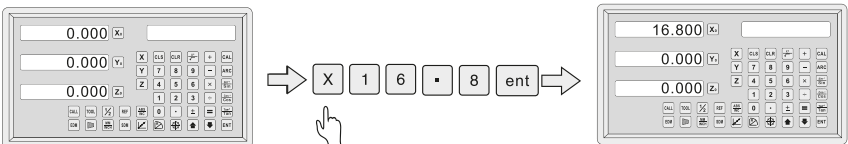

### 3. Basic Functions

#### 3.4 1 / 2 Function

**Function:** to find the centre of the workpiece

**Example:** To find the centre of the workpiece of X-Axis.

**Step 1:** Touch one side of the workpiece with the TOOL, then zero the X-Axis.

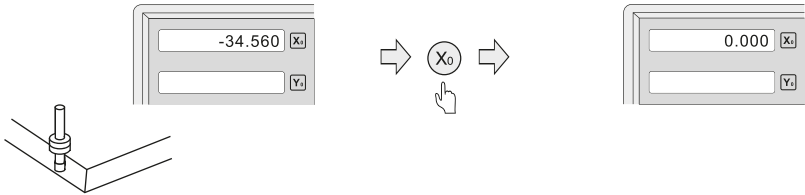

**Step 2:** Take the TOOL to the opposite side of the workpiece and touch it.

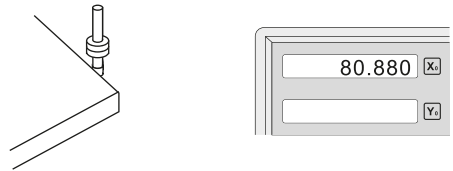

**Step 3:** Execute the workpiece centering of the X axis as per follow

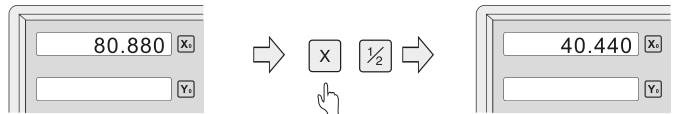

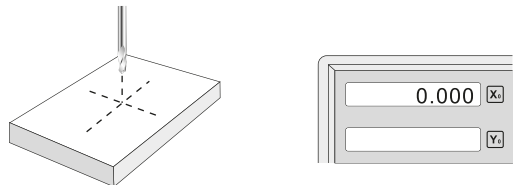

**Step 4:** Retract the axes until the displays read 0.000, the TOOL can be placed exactly at the center of the workpiece.





### 3. Basic Functions

#### 3.5 ABS/INC Mode

**Description:** There are two set of basic coordinates display, ABS (absolute) and INC (incremental) displays. During machining operations, operator can store the workpiece datum (zero position) in ABS coordinate, then switch to INC coordinate for continue machining operations. ABS and INC can be simply toggle by pressing 

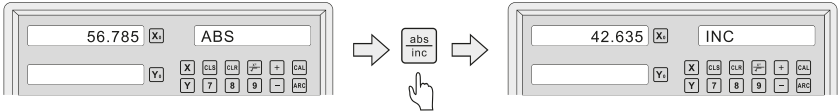
**Example:** currently in ABS mode. To toggle to INC mode by pressing 



**Example:** currently in INC mode. To toggle to ABS mode by pressing 

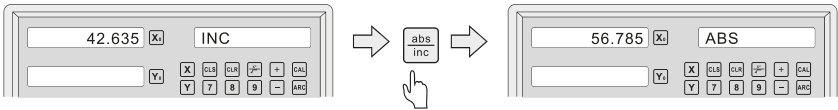

#### 3.6 Clear 200 sets Sdm datum

In ABS Mode, To continuously press the key  ten times will cause to clear all the datum for 200 sets Sdm.

#### 3.7 NON-VOLATILE MEMORY

The memory is used to store the settings of the DRO and machine reference values when power is turn off.

#### 3.8 Sleeping Mode

In not ABS Mode, pressing the key  can turn off all the display and the DRO accessing to the Sleeping Mode. , then pressing this key again will cause the DRO back to the working Mode. In the Sleeping Mode the DRO is still in working state and actually records the TOOL movement.

**Example:** In not ABS Mode, to access the sleeping Mode by pressing the key 

In Sleeping Mode, pressing the key  to quit the sleeping Mode.

### 3. Basic Functions

#### 3.9 Ref datum memory function:

During the daily machining process, it is very common that the machining cannot be completed within one work shift, and hence the DRO have to be switched off after work, or power failure happen during the machining process which is leading to lost of the workpiece datum (workpiece zero position), the re-establishment of workpiece datum using edge finder or other method is inevitably induce higher machining in accuracy because it is not possible to re-establish the workpiece datum exactly at the previous position. To allow the recovery of workpiece datum very accurately and no need to re-establish the workpiece datum using edge finder or other methods, every Linear scale have a ref point location which is equipped with ref position to provide datum point memory function.

The working principal of the ref datum memory function are as follows.

Since the ref point of Linear scale is permanent and fixed, it will never change or disappear when the DRO system is switched off. Therefore, we simply need to store the distance between the ref point and the workpiece datum(zero position) in NON-Volatile memory. Then in case of the power failure or DRO being switched off, we can recover the workpiece datum (zero position) by presetting the display zero position as the stored distance from the ref point.

Example: to store the X axis work datum.

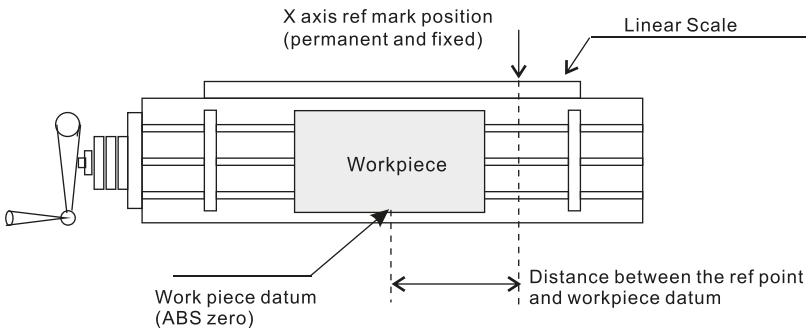

After power failure, the workpiece datum can be recover by presetting this distance from the ref mark position.

Operation: DRO provides one of the most easy to used ref datum memory function. There is no need to store the relative distance between the ref mark and your work datum zero into DRO, whenever you alter the zero position of ABS coordinate, such as by zeroing, center find, coordinate preset or etc..., DRO will automatically store the relative distance between ABS zero and the ref mark location into the memory of DRO.

In daily operation, operator simply need to find the ref mark position whenever they switch on the DRO to let DRO know where the ref mark position is, then DRO will automatically do the work datum storage on its own whenever you alter the ABS zero position. In case power failure or the DRO switched off, the operator can recover the workpiece datum easily by the RECALL 0 procedure.

### 3. Basic Functions

**3.9.1 Find Ref:** the DRO can automatically store the relative distance between the ref mark position and the ABS datum (zero position) whenever the operator alter the ABS zero position, such as zeroing, centra find, coordinate preset or etc...

Therefore, DRO need to know where the ref position in prior to machining operation. In order to avoid the lost of work piece datum (zero position) during any accidental or unexpected events, such as power failure or etc..., It is highly recommend that operator find the ref mark position using the (FIND REF) function whenever they switch on the DRO.

**Step 1:** Enter the Ref function and select the FIND REF (find ref mark)

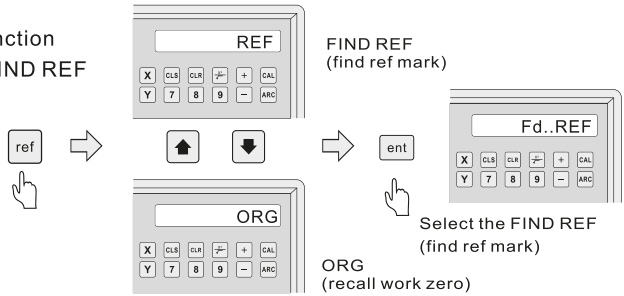

**Step 2:** Select the axis of which ref mark needed to be found

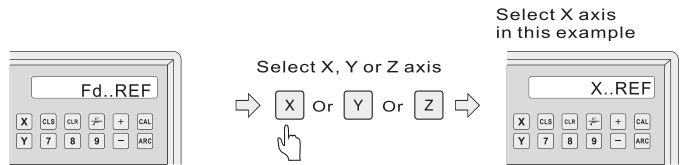

**Step 3:** Move the machine across the centra or the left or the right of the Linear scale until the right window flashes FIND X, then display FD...REF. Press **Y** for FIND REF Y and the key **Z** for FIND REF Z.

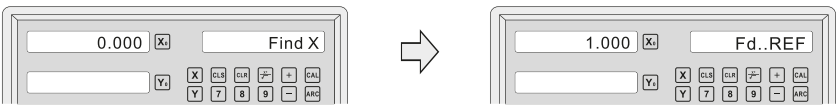

Move the machine across the ref mark point

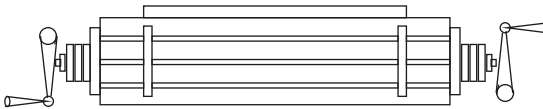

**Step 4:** Press **ref** to quit Ref function.



### 3. Basic Functions

#### 3.9.2 Recall work zero

**Step 1:** Enter the ref function and select the FD ORG (recall workpiece zero)

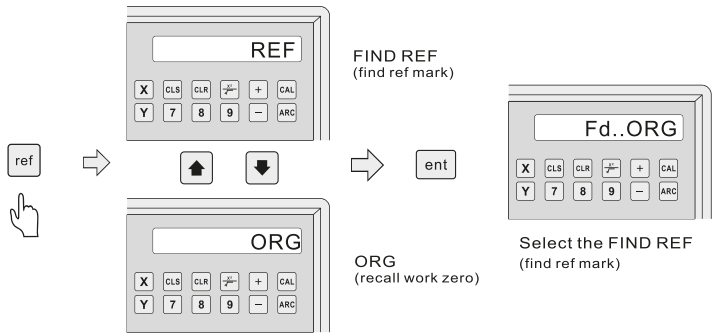

**Step 2:** Select the axis of which work datum(zero position) needed to be recovered

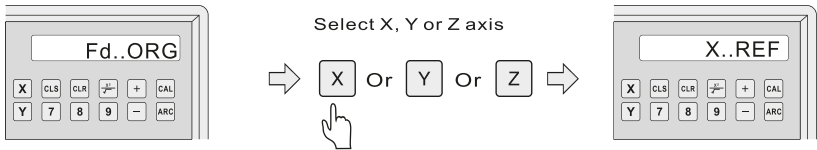

**Step 3:** Move the machine across the centre or the left or the right of the Linear scale until the right window flashes FIND X, then display FD...ORG. Press **Y** for FIND ORG Y and the key **Z** for FIND ORG Z.

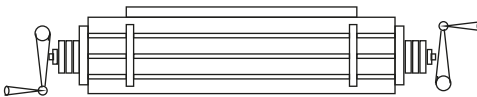
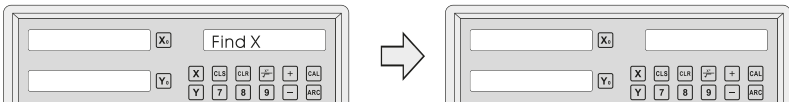

Move the machine across the ref mark point

**Step 4:** After find ORG X, Y and Z; move the machine to display value=(0.000), the TOOL is exactly located at the ABS zero.

### 3. Basic Functions

#### 3.10 Linear Compensation

Setting Linear compensation to rectify the system error of the digital readouts system.

Rectifying coefficient  $S = (L - L1) / (L - 1000)$  mm/m

L: the actual length value, unit: mm

L1: the display value, unit: mm

S: Rectifying coefficient. Unit: mm/m

Regarding the polarity, select a positive(+) compensation when displayed value is smaller than the actual length and negative(-) compensation when the display value is greater.

Compensation range: -1.500mm/m to +1.500mm/m

**Example:** the actual value is 1000mm and the display value is 999.98mm

$$S = (1000.000 - 999.880) \div (1000.000 \div 1000.000) = 0.120$$

**Step 1:** Press  $\boxed{X}$  to select the x axis and press  $\boxed{\frac{mm}{inch}}$  to access the setting Linear compensation.

**Step 2:** Input rectifying coefficient 0.12 as follow

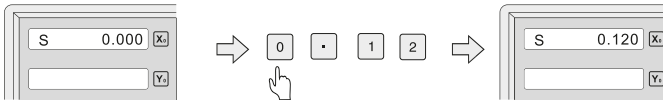

#### 3.11 Non-Linear Error Compensation

First compensation Type ( Linear or Non-Linear) in parameter setting must be set Non-Linear.

**Step 1:** Move the worktable to the left ,  
and press the key  $\boxed{\frac{abs}{inc}}$  to enter ABS display Mode

**Step 2:** Press the Key  $\boxed{X}$  , then press  $\boxed{\frac{mm}{inch}}$  to enter  
parameter setting for Non-Linear compensation.



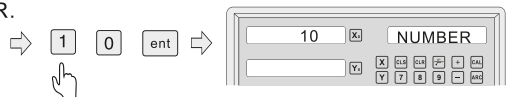

**Step 3:** Input the parameter NUMBER.



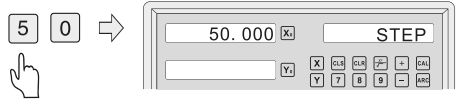

### 3. Basic Functions

Step 4: Input the parameter STEP.  
(For example : STEP = 50)

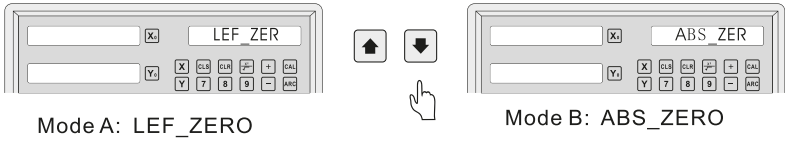

Step 5: Select the start point (There are two kinds of start point a. LEFT ZERO;  
b. ABS Ref ZERO and can be selected by pressing key  



In Mode A (LEF\_ZERO), the start point is find by pressing the key 

In Mode B (ABS\_ZERO), the start point is find by moving the worktable.

The start point is the start point for calculation of Non- Linear compensation.

Step 5: Input compensation value.

X-axis display the value of the Digital Readout

Y-axis display the real value ( input by the operator)

the error must be less than 10%.



Step 6: After input all parameter, the DRO automatically exit .

### 3. Basic Functions

#### 3.12 200 sets Sub Datum Function:

There are three kinds of coordinate systems. ABS Mode (1 set), INC Mode(1set) and SdM Mode (200 sets). It is a good way to store the datum of workpiece in ABS Mode and to machine in INC or SdM Mode. INC is independent of ABS, it is not relative to ABS datum. However, all Sdm coordinate are relative to ABS coordinate, the SdM position will shift together with the ABS zero position change.

ABS Mode , INC Mode and SdM Mode are specially designed to provide much more convenience features to the operator to cope with the batch machining of repetitive works and the machining of the workpiece machining dimensions from more than one datums.

Application to the workpiece that have more than one datums

Store all the subdatums of workpiece as per follow.

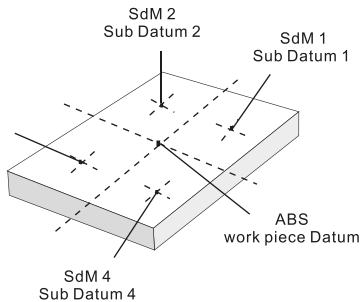



Go to the SdM directly by pressing the Number of SdM in SdM state or pressing  

Application to the batch machining of repetitive works

Because all SdM subdatums(0.000) are relative to ABS datum, therefore, for any repetitive works, the operator just need to set up the first workpiece datum at ABS and store the machining position in SdMs.

For anymore repetitive parts, just set up the 2nd, 3rd... Workpiece zero at ABS, then all the machining positions will reappear.



Go to the SdM directly by pressing the Number of SdM in SdM state or pressing the key  

Move the TOOL to display= 0.000, then machining location reached.

### 3. Basic Functions

#### Example:

There are four auxiliary zeros (sdm1 to sdm4). There are two methods to set the auxiliary zeros. One is zeroing when reaching position and the other is directly input sdm zero. The example, as follow, the sdm coordinates are all related to ABS zero.

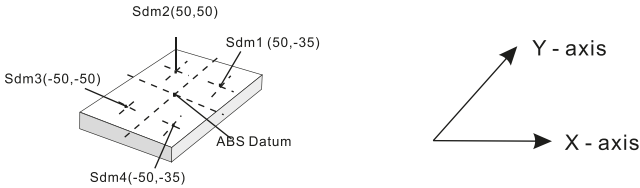

#### Method 1: Zeroing when reaching Position

Move worktable to place the TOOL at the central point for the workpiece, then enter display way of ABS. Zeroing, set ABS zero in the main reference point of parts.

##### Step 1: Set the origin of ABS ( the reference of the workpiece)

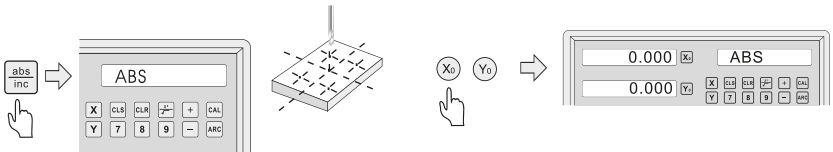

##### Step 2: Set the origin of sdm 1

In ABS Mode, Move the machine worktable to X=50.000,Y=-35.000

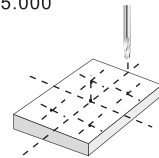
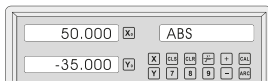

Enter sdm 1 coordinate as follow

Zero to X axis and Y axis as follow

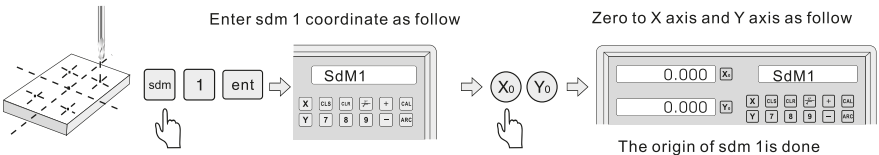

### 3. Basic Functions

#### Step 3: Set the origin of Sdm 2

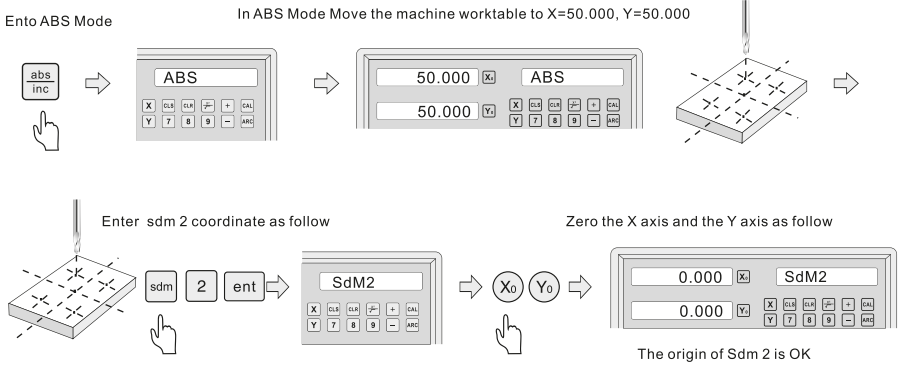

#### Step 4: Set the origin of Sdm 3

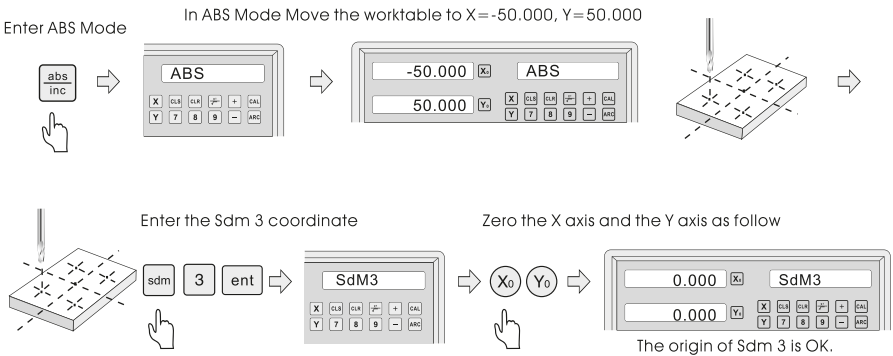

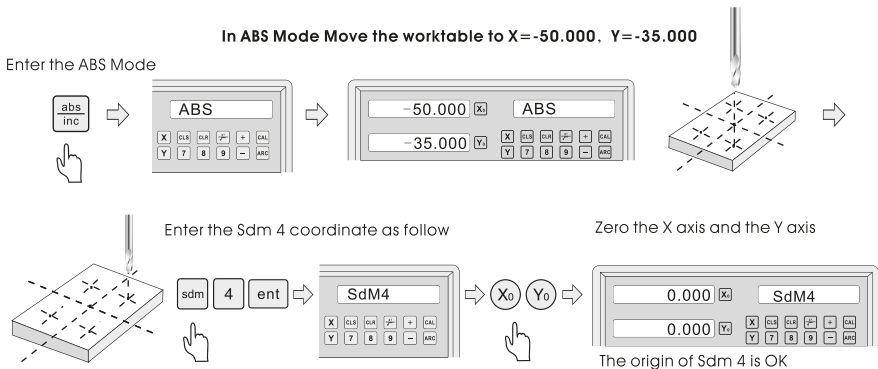

#### Step 5: Set the origin of sdm 4



### 3. Basic Functions

To ACK the origin of Sdm

Press   to the sdm coordinates done and ACK the value.

Example:

The Value is related to the origin of ABS coordinate

Enter Sdm 1 coordinate to ACK the value

The Value is related to the origin of sdm 1 coordinate

Enter the Sdm 2 coordinate

The Value is related to the origin of Sdm2 coordinate

Enter the Sdm 3 coordinate

The Value is related to the origin of Sdm 3 coordinate

#### Method 2: Directly input

There are the same sample as Method 1. First Move the worktable to place the TOOL exactly at the origin of ABS, secondly Enter the ABS Mode as follow.

Step 1: Set the origin of ABS

Move the worktable to place the TOOL at the origin of ABS

Enter the ABS Mode

Zero the origin of ABS Mode as follow

The origin of ABS is OK.

### 3. Basic Functions

#### Step 2: Set the origin of Sdm 1 coordinate.

Enter the Sdm 1

sdm 1 ent

Input the contrary value (-50,35) of the coordinate Value as follow

X 5 0 ent

Y 3 5 ent

SdM1

-50.000 X SdM1

35.000 Y X CLR CLR CLR + CAL

Y 7 8 9 - ARC

Y 7 8 9 - ARC

Note : the input value and the coordinate value is contrary.  
Reason: the TOOL is at the origin of ABS Mode. AS the input value is contrary to the coordinate, Retract the axes until the displays read 0.000, the TOOL can be placed exactly at the origin of the Sdm.

#### Step 3: Set the origin of Sdm 2

Enter the Sdm 2

sdm 2 ent

Input the contrary value(-50,-50) of the coordinate value as follow

X 5 0 ent

Y 5 0 ent

SdM2

-50.000 X SdM2

-50.000 Y X CLR CLR CLR + CAL

Y 7 8 9 - ARC

Y 7 8 9 - ARC

The origin of Sdm 2 is done.

#### Step 4: Set the origin of Sdm 3

Enter the Sdm 3

sdm 3 ent

Input the contrary value(50,-50) of the coordinate value as follow

X 5 0 ent

Y 5 0 ent

SdM3

50.000 X SdM3

-50.000 Y X CLR CLR CLR + CAL

Y 7 8 9 - ARC

Y 7 8 9 - ARC

The origin of Sdm 3 is done.

#### Step 5: Set the origin of Sdm 4

Enter the Sdm 4

sdm 4 ent

Input the contrary value(50,35) of the coordinate value as follow

X 5 0 ent

Y 3 5 ent

SdM4

50.000 X SdM4

35.000 Y X CLR CLR CLR + CAL

Y 7 8 9 - ARC

Y 7 8 9 - ARC

The origin of Sdm 4 is done.



## 4. Special Functions

## 4. Special Functions

### 4.1 Linear Drilling

There are two modes to carry out the Linear Drilling

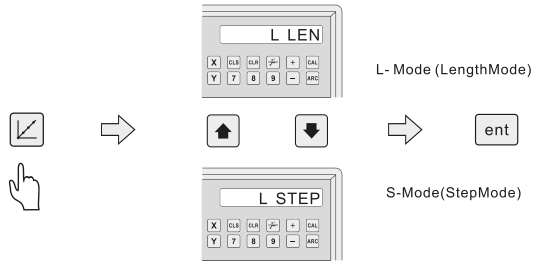

To input the following data

L-Mode: LENGTH--Length of oblique line--the distance of the centers of the starting hole to the ending hole

ANGLE -- It indicates the direction of oblique line on the coordinate plane.

AS the Fig( ), the intersection angle A is 30. The intersection angle B is -30.

No.Hole

S-Mode: STEP -- the distance of two adjacent holes.

ANGLE -- the same as ANGLE of L-Mode

No.Hole

Example: As the left Fig.

The Length :60mm

The angle :30

Hole Number :4

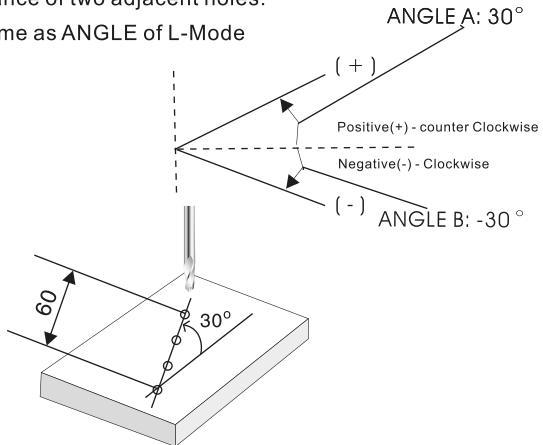

Step 1: To access the Linear Drilling by pressing and selecting the L-Mode

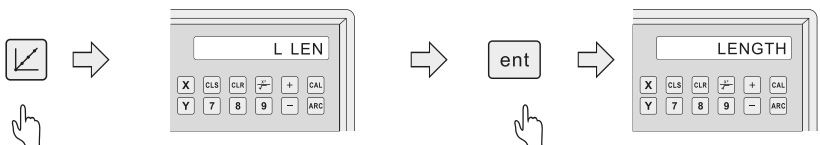

## 4. Special Functions

**Step 2:** Input the LENGTH:

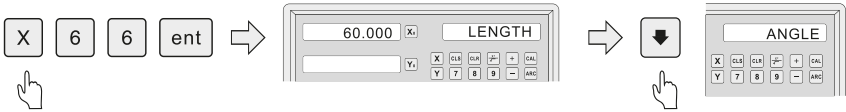

**Step 3:** Input the ANGLE:

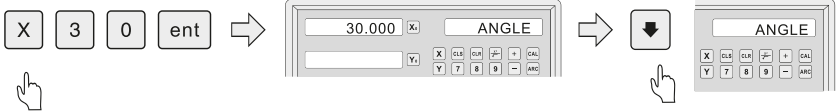

**Step 4:** Input the Number Hole.

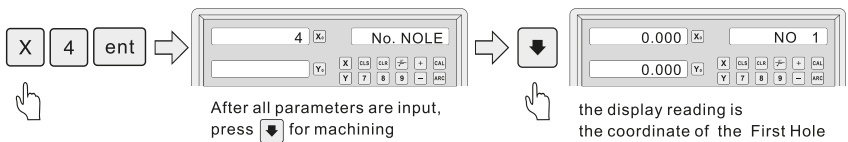

**Step 5:** Press the key to display the position of next hole. Retract the axes until the displays read 0.000, the tool can be placed exactly at the position of the hole. Press to quit the Function at any time.

### 4.2 PCD Function

The Function of PCD Hole positioning on Circumference is used to distribute arc equally, such as boring hole on flange. The right window will show the parameter to be defined when selecting PCD Function. The Parameters to be defined are:

CT POS -- the central coordinate of arc

DIA -- Arc diameter

No.Hole -- Number of equipartition points

AT ANGLE -- Starting angle of arc to be distributed equally.

ED ANGLE -- Ending angle of arc to be distributed equally.

Note: the direction of starting angle and ending angle is shown as the right Fig

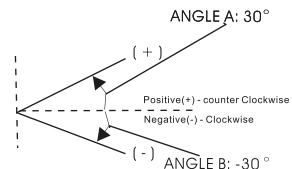

Take the machining of the work-piece in Figure as an example

**Step 1:** Press to enter PCD Function and select the processing plane X-Y for 3 axes

**(when using DRO for 2 axes, goto the next parameter without selecting processing plane)**

## 4. Special Functions

**The Parameters of the example:**

CT POS-----X=0.000, Y=0.000  
 DIA-----80mm  
 No.HOLE---5  
 ST ANG-----30  
 ED ANG-----300

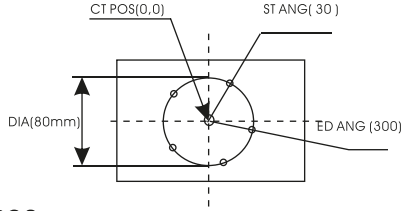

**Step 2: Input the first parameter -- CT POS**

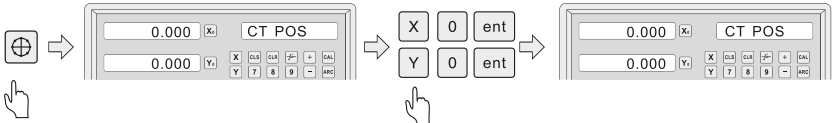

**Step 3: Input the diameter (DIA)**

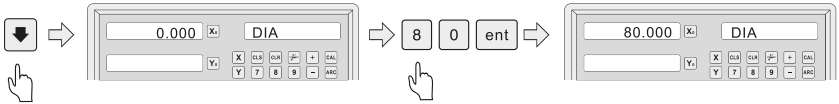

**Step 4: Input the start angle of the first Hole(ST ANG)**

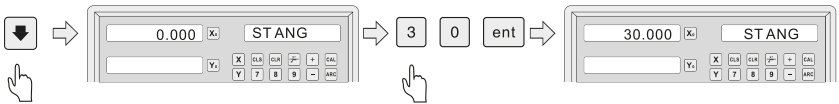

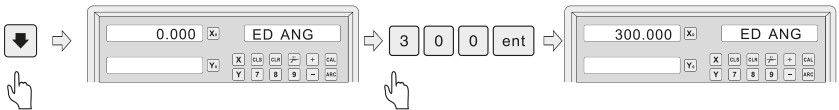

**Step 5: Input the end angle of the end Hole(ED ANG)**



**Step 6: Input the Number of hole ( NO.Hole)**



**Step 7: After all parameters are input, Press the Key  for machining..**

Press the key  to display the position of the hole. Retract the axes until the displays read 0.000, the TOOL can be placed exactly at the position of the hole.

Press  to quit the Function at any time.

## 4. Special Functions

### 4.3 R Function (applicable to: milling machine, Boring machine)

Two functions are available for the R function: the simple R Function and the smooth R function. Their advantages and limitations are as per follows.

**Smooth R function:** provides maximum flexibility in R machining, the R sector to be machined by the coordinates of R

1) R centre; 2) R Radius; 3) R start angle; 4) R end angle..



**Advantage:** Very flexible, R function can machine virtually all kinds of R, ever the intersected R.

**Limitation:** Relatively a bit complicated to operate, operator need to calculate and enter the coordinates of R centre, start angle and end angle.

**Simple R function:** is aimed to machine only simple R or round corners, DRO provides the eight type of most frequently used R machining process.

**Advantage:** Very easy to use, operator does not even need to calculate the R parameters, just posit the TOOL at the start point and the type of machining, and then can start the R machining right away..

**Limitation:** Restricted to eight type of preset R only, cannot machine more complicated R such as intersected R.

Press  to enter R function, then press   for selecting Smooth R Function or Simple R Function.

Before using the R Function, operators shall understand as follows.

- 1) the coordinate system and the direction of X, Y and Z axis of the machine ..
- 2) the angle and the polarity of angle.

During installation, normally the coordinate of the machine and the direction of X, Y, Z are as per follow. The work plane is shown as the right Figure.

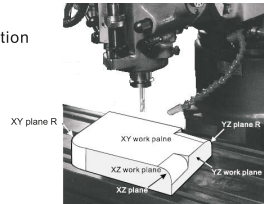
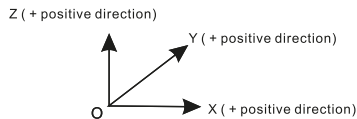

**Example:** Understand coordinate system. (On any of plate XY, XZ or YZ the coordinate of a point is the position relative to the zero one the plate)

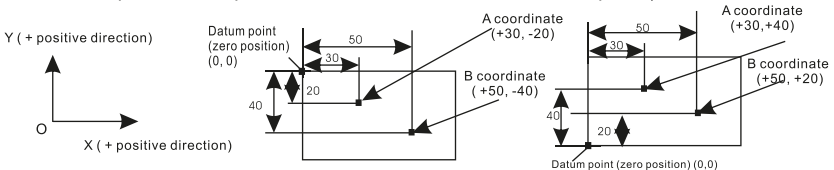

**Example:** understand the Angle. (On any of plate XY, XZ or YZ both the start angle and end angle of R is calculated in counter-clockwise)

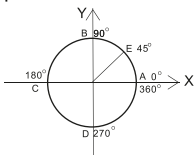

**Arc AB** ( from A to B; the start angle A is 0, the end angle B is 90.)  
(From B to A: the start angle B is 90, and the end angle A is 0.)



**Arc ED**( from E to D; the start angle E is 45, and the end angle D is 270.)  
(from D to E: the start angle D is 270, and the end angle E is 45.)

## 4. Special Functions

### 4.3.1 SMOOTH R Function

Procedure for using the SMOOTH R function:

Install and fix the workpiece in accordance with figures(A, B, C) and set the TOOL.

1. Move the TOOL to the start point and Clear every axis.  
( make the TOOL setting position to the zero).
2. Press  to enter R function and press   to select the SMOOTH R function:
3. Select work plan -XY, XZ or YZ plane R  
( ARC-XY, ARC-XZ, ARC-YZ)
4. Input the parameter CT POS :  
CT POS is refer to the position of the centre of an arc relative to that of the TOOL at TOOL setting and clearing.

When plane XZ or YZ is machined

As shown in figure (b). It refers to the position of point O at the centre of the arc relative to point B of the TOOL when a planar milling TOOL is used.

AS shown if figure (c), it refers to the position of point O at the centre of the arc relative to point C of the TOOL when an arc milling TOOL is used.

When plane XY is machined

As shown in figure (a), it refers to the position of point O at the centre of the arc relative to the central spindle of the TOOL

5. Input the parameter of R (the radius of the Arc )
6. Input the parameter of TL DIA ( the diameter of the TOOL)

Note: when Arc on plane XZ or YZ are machined: as shown in figure (b), a planar milling TOOL shall be used to machine R with point B as the machining point, and the diameter of the TOOL has no impact on the machining, so please input the TL DIA = 0.

7. Input the parameter of MAX CUT

Note: For XY plane Arc, MaxCUT = max distance between interplotted points.

For XZ / YZ plane R:

- 1) MAX CUT = max distance between interplotted points in SMOOTH R function
- 2) MAX CUT = Z STEP (fixed increment per step) in SIMPLE R function.



Figure A



Figure B

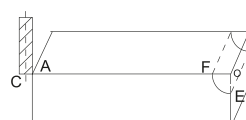



Figure C

8. Input the parameter of ST ANG ( the angle of the start point of the Arc)
9. Input the parameter of ED ANG ( the angle of the end point of the Arc)

## 4. Special Functions





10. Press  or  to Select R+TOOL(for outer Arc) or R-TOOL (for inner Arc)

As shown the right figure: R + TOOL for outer arc and R - TOOL for inner arc

11. After all parameters are input, Press the Key  for machining.

The DRO will display the position for machining. Retract the axes until the displays read 0.000, Machine the Arc point by point in accordance with the display.

Press  to quit the Function at any time.

	R + TOOL	R - TOOL
XZ/YZ plane R		
XY plane R		

Example: ( for SMOOTH R FUNCTION)

To machine an XY plane R, machining parameters as per follow.

1. Move the TOOL to the start point and clear every axis.

(Make the TOOL setting position to the zero).

2. Select XY plane R

3. CT POS = (20, -20)

4. R = 20.000

5. TL DIA = 6.000

6. MAX CUT = 0.3

7. ST ANG = 0

8. ED ANG = 90

9. R + TOOL ( outer arc machining )

Step 1: Press  to enter R function, select SMOOTH R function.



Step 2: Select work plane ( ARC\_XY ) .



Step 3: Input CT POS  
(the coordinate of the centre) .

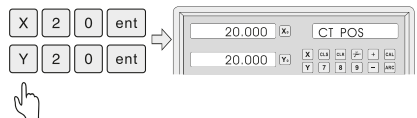

## 4. Special Functions

Step 4: Input R (the radius of R)

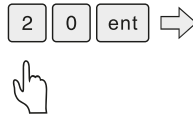

Step 5: Input TL DIA (the TOOL diameter)

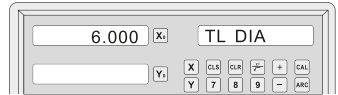
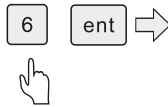

Step 6: Input MAX CUT.



Step 7: Input ST ANG ( the angle of the first point)

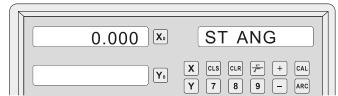
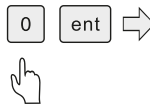

Step 8: Input ED ANG (the angle of the end point)

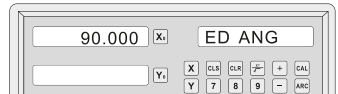
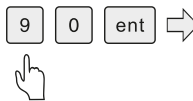

Step 9: Select the machining mode of the inner or outer arc.



Step 10: After inputting all parameters, press the key  for machining. The DRO will display the position of the first point. Move the machine TOOL until the axis is displayed as zero to get R starting point.

Press  to quit R function any time.



## 4. Special Functions

### 4.3.2 The SIMPLE R function

When the smoothness is not highly demanded, the SIMPLE R function is normally used for machining Arc. In the SIMPLE function there are only eight type of ARC used to machine. The operator just select the type of R and input the parameters of the radius of Arc , MAX CUT and outer Arc or inner Arc. In general, an arc may be machined by a planar slot TOOL or arc TOOL , the different between them in different work plane as shown as per follows.

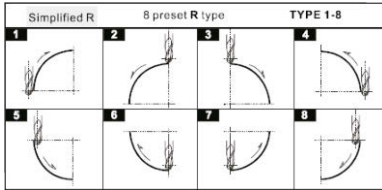

Figure 1:Using an arc lot TOOL for XZ/YZ plane Arc

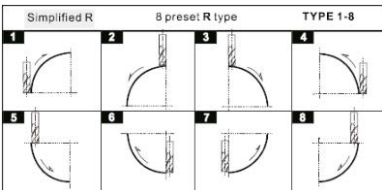

Figure 2: using a planar TOOL for XZ/YZ plane Arc

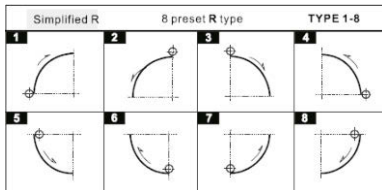

Figure 3: Using two Flute for XY plane Arc

Procedure for using the SIMPLE R function:

1. Make the TOOL over against the arc starting point (refer to the left figure ) and clear every axis to make the TOOL setting position to the zero
2. Press to enter R function and press the key to select Simple R function.
3. Select R machining Mode which has been preset as type 1 to type 8.
4. Select XY, YZ or YZ as the machining plane. ( ARC-XY, ARC-XZ, ARC-YZ)
5. Input the parameter of A .  
( the radius of the Arc )
6. Input the parameter of TL DIA.  
( the diameter of the TOOL )  
Note: (refer to step 6 of SMOOTH R Function)  
use a planar TOOL to machine arcs on plane XZ or YZ and input TL DIA = 0;

#### 7. Input the parameter of MAX-CUT .

Note: For XY plane Arc, MaxCUT = max distance between interplotted points.

For XZ / YZ plane R:

- 1) MAX CUT = max distance between interplotted points in SMOOTH R function
- 2) MAX CUT = Z STEP (fixed increment per step) in SIMPLE R function

8. Press or to select R+TOOL (for outer Arc) or R- TOOL ( for inner Arc)  
(Refer to step 10 of SMOOTH Function for outer arc and inner arc)
9. After all parameters are input, Press the Key for machining..

The DRO will display the position for machining. Retract the axes until the displays read 0.000, Machine the Arc point by point in accordance with the display.

Press to quit the Function at any time..

## 4. Special Functions

Example: To machine the workpiece as shown Figure

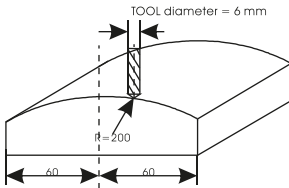
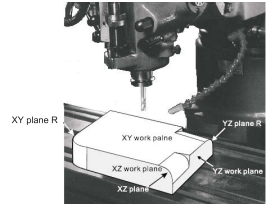
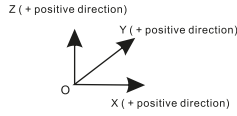
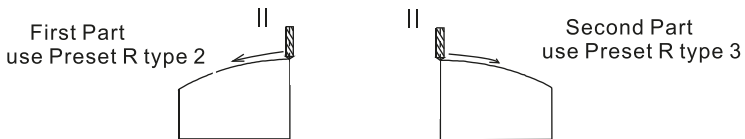

Figure 1:





Divide the machining into two parts for using the SIMPLE R function

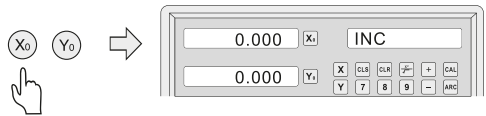

Step 1. Make the TOOL over against the arc starting point (refer to the figure ) and clear every axis to make the TOOL setting position to the zero .



Step 2: Press  to enter R function.  
press   to select Simple R function as per follows.

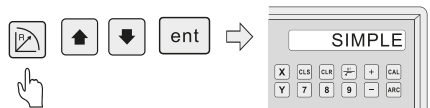

Step 3: Select preset R type.  
( TYPE 2 for 1st part of workpiece)  
(TYPE 3 for 2nd part of workpiece)

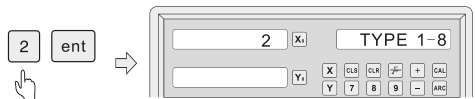

Step 4: Select the work plane ( ARC\_XZ)

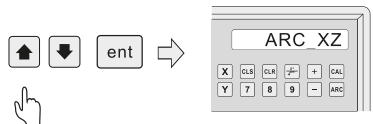

## 4. Special Functions

Step 5: Input R = 200.

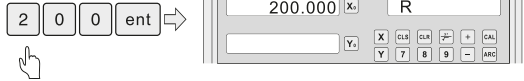

Step 6: Input the TL DIA = 6



Step 7: Input the MAX CUT = 0.3.



Step 8: Select the machining mode of the inner or outer arc.

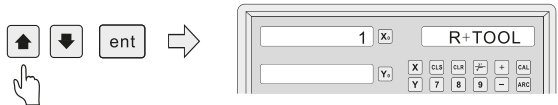

Step 9: After inputting all parameters, press the key **ent** for machining.

The DRO will display the position of the first point. Retract the axes until the displays read 0.000, Machine the Arc point by point in accordance with the display.

Press  to quit R function any time.

## 4. Special Functions

### 4.4 Chambering ( applicable to: Milling machine, Boring Machine)

Enter chambering function. Input parameters: center coordinate, chamber length, chamber width, TOOL diameter.

Example: Machining the part chamber shown in Figure A, Align TOOL as Figure A.

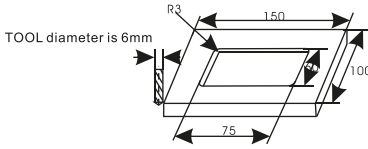

Figure A

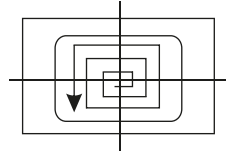
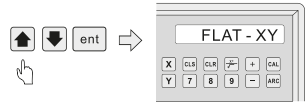
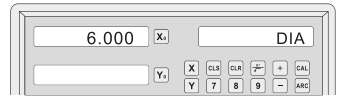

Figure B

**Step 1:** Press to enter the Chambering Function and to select work plane XY plane as the right.. (FLAT-XY, FLAT-XZ, FLAT-YZ).



**Step 2:** Input the TOOL diameter



**Step 3:** Input the center coordinate:

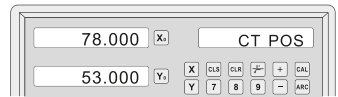

**Step 4:** Input the size  
(the chamber length  
and the chamber width)

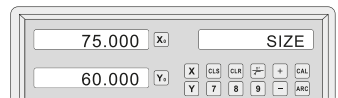
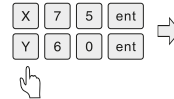

**Step 5:** After all parameters are input.  
Press for machining.

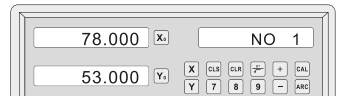

Machining state is ON

Move the machine until the display of the axis is zero, ie, the position of the first point. Machine the first point . Display the next machining point by pressing . On the completion of machining, the right window shows OVER. Press , the system will goto the first position for the next workpiece.

Press to quit the Chambering Function.

## 4. Special Functions

### 4.5 TOOL compensation Function (Applicable to : Milling machine)

Without TOOL compensation, the operator has to move the TOOL for an additional distance of the diameter of the TOOL along each side when machining the four 150 and 100 sides of a workpiece to finish machining the whole brim. The digital readouts shall automatically compensate when the TOOL compensation function is enable.

Note: the TOOL compensation is made in the direction of X-axis and Y-axis.

Procedures:

- 1). Enter the function of compensating the diameter of the TOOL.
- 2). Select one of the(four) preset machining modes.
- 3). Input the diameter of the TOOL.
- 4). Enter machining.

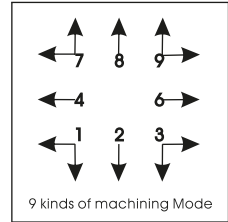

Example: As shown below. Machining the plane A & B of workpiece shown in Figure.

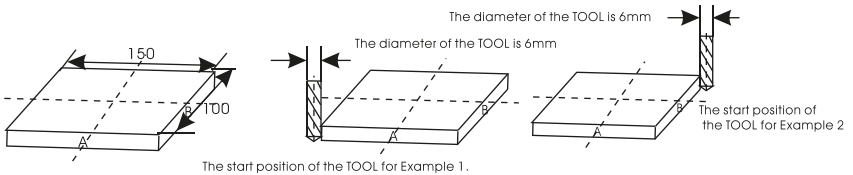

Step 1: Press **Tan<sup>1</sup>** to enter the TOOL compensation Function.



Step 2: Input the Machining Mode.

Example 1: select the Machining Mode 9

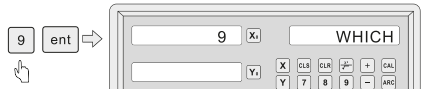

Example 2: select the Machining Mode 1



Step 3: Input the diameter of the TOOL

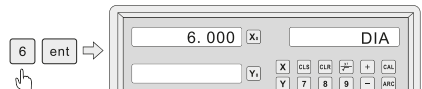

Step 4: Press **ent** to the machining Mode.

Machining of 2 side planes can be done by moving the TOOL until X-Axis is 150.000 and Y-Axis is 100.000.

Press the Key **Tan<sup>1</sup>** to quit the Function.

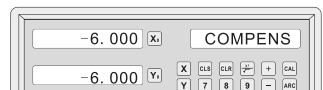

Enter the machining with the TOOL compensation Function ( Example 2 : WHICH = 9)

## 4. Special Functions

### 4.6 Machining of oblique plane (applicable to: Milling Machine)

There are 2 ways available for machining oblique plane:

- a) on the plane XY ; b) on the plane YZ, or XZ.

#### 4.6.1. XY plane

When the machining plane is on plane XY as the part shown in Figure 1, the angle of obliquity of the workpiece should be calibrated before the oblique plane is machined. Therefore, at this point the machining of oblique plane plays the role of calibrating the obliquity.

Procedure for calibrating the obliquity

First place the workpiece on the worktable as per the required angle of obliquity.

- 1) Enter the function of oblique plane.
- 2) Select the function of plane XY .
- 3) Input the angle of obliquity.
- 4) Move the worktable until the measuring tool (such as a dial gauge) installed on the milling machine touches the obliquity-calibrating plane, adjust it to zero, and move the worktable for any distance in the direction of X-axis.
- 5) Move the worktable in the distance of Y-Axis until the display turns to zero.
- 6) Change the angle of the work piece to make the workpiece touch the measuring tool and adjust it to zero.

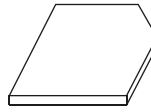

Figure 1

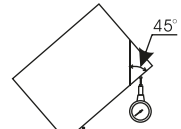



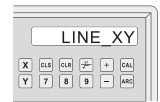

Figure 2

For example: calibrate the obliquity of the workpiece to 45 degree shown in Figure 2.

- Step 1:** Place the work piece on the worktable at the obliquity of about 45 degree. Press  to enter the Machining of Oblique Plane Function. Press    to select X Y plane



- Step 2:** Input the angle of obliquity.

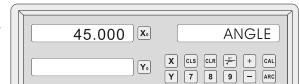
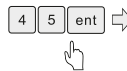

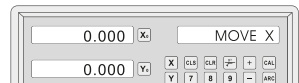

- Step 3:** Move the workpiece along the X-Axis until the measuring tool touches the workpiece adjust it to zero, and move the worktable for any distance along the X-Axis.

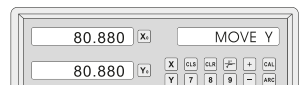

- Step 4:** Press , display the value of Y-Axis. Move the workpiece along the Y-Axis, change the angle of workpiece to make the obliquity-calibrating plane touch the measuring tool until it turns to zero.

Move the worktable until Y-Axis is displayed as zero.



- Press  to quit at any time.

## 4. Special Functions

### 4.6.2 XZ or YZ plane

When the machining plane is on plane XZ or YZ, the function of TOOL inclination can instruct the operator to machine the oblique plane step by step.

Procedures for using the function of cutter inclination:

When the machining plane is on plane XZ or YZ, first please calibrate the obliquity of the primary spindle nose and set the TOOL

- 1) Select the machining function
- 2) Input the starting point ( ST POS)
- 3) Input the end point (ED POS).
- 4) Input the diameter of the TOOL (DIA).
- 5) machining the oblique plane.

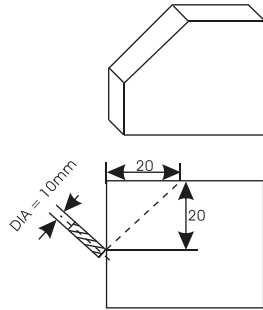
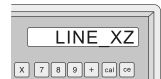

Figure 1

**For example:** machining the obliquity of the workpiece to 45 degree on X Z plane shown in Figure 1.

**Step 1:** Press  $\frac{\sin^{-1}}{\sin}$  to enter the Machining of Oblique Plane Function.

Press  $\uparrow$   $\downarrow$   $\text{ent}$  to select X Z plane



**Step 2:** Input the parameter DIA (the diameter of the TOOL)

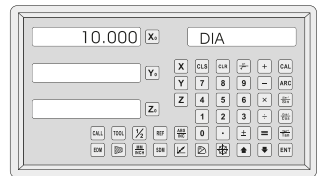

**Step 3:** Input ST POS (the starting coordinate)

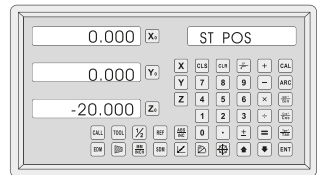
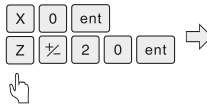

**Step 4:** Input ED POS (the end coordinate)

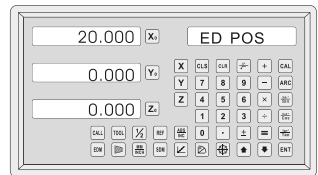
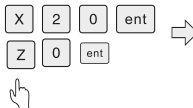

**Step 5:** After input all parameters, press  $\text{ent}$  to enter the machining state. AS shown right  
The displayed value is the coordinate of the first point. Move the Machine TOOL until X-Axis and Z-Axis are all displayed as zero. Repeat it until over.

Press  $\frac{\sin^{-1}}{\sin}$  to quit this function at anytime.

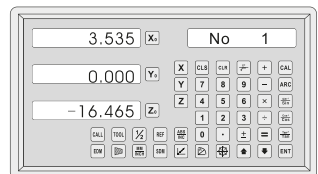

## 4. Special Functions

### 4.7 Calculator

The Calculator not only provides normal mathematical calculations such as +, -, X, /, it also provide trigonometric calculations such as SIN, Arc SIN, COS, Arc COS, TAN, Arc TAN SQRT etc.

The Operations are same as the commerical calculators, easy to use.

Key layout of the calculator:

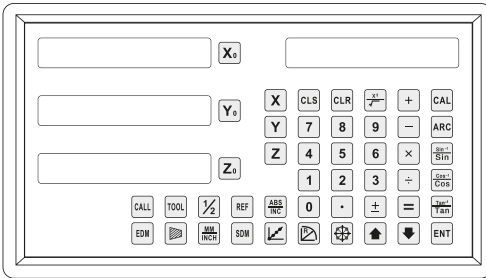

Calculator key  
to call the calculator function

Arc key  
for trigonometric calculators

#### Example 1: $10+10\div 2\times 5=35$

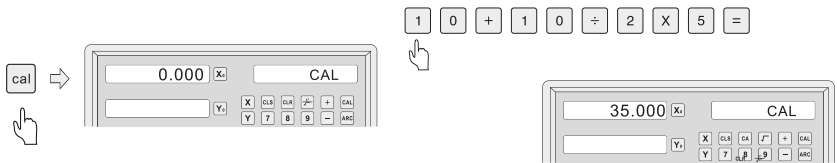

#### Example 2: $\text{SIN}45=0.707$

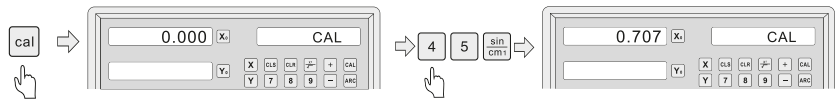

#### Example 3: Arc Sin 0.707=44.991

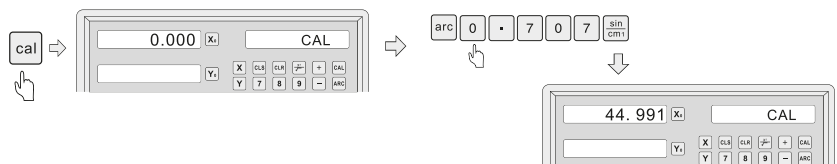



## 4. Special Functions

### 4.8 Machining Function of the Grinding Machine

#### 4.8.1 Digital Filter

In grinding processing, the vibrating of grinding machine makes the display of readout change repeatedly and rapidly and it causes the uncomfortable vision of operators. The special readout DRO\_2G for grinding machine has the function of digital filtering, that is the "Removing shutter function". In grinding processing, operator can use the function following the below operation.

**Step1:** Press the key  to access the filter Function.

S Mark is appear in the left of info window

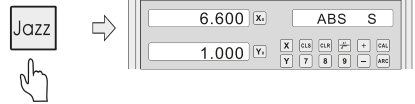

**Step2:** Press the Key  again to quit the filter function.

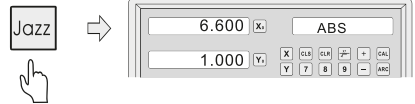

**Note:** The display value filtering function can be only used in the INC and ABS state.





## 4. Special Functions

### 4.9 Machining Function of Lathe

#### 4.9.1 200 sets TOOL Libs

It always needs different TOOL when processing different parts. For convenient operation, DRO-2L and DRO-3L digital readouts has the function of 200 sets TOOL Libs.

Note: Only when the lathe is equipped with the tool setting block, the 200 sets TOOL Libs can be used.

1. Set a datum TOOL. After tool setting, Zero X axis and Z axis, the set zero of absolute coordinate.
2. According to the size of TOOL1 and datum TOOL, determine the position of TOOL relative to zero of absolute coordinate and datum tool. As Figure 6-1. The relative size of TOOL 2 is as follows X axis  $25-30=-5$ , Z axis  $20-10=10$ .
3. Save the TOOL number and the size into digital readout.
4. The number of TOOL can be input at random, the digital readouts will display the position of tool to absolute coordinate zero. Move lathe until X axis and Z axis both display zero.
5. TOOL Libs can save the 200 sets of the data of tools.
6. The TOOL Libs must be use in the opening state. The 200 sets TOOL Libs can be opened by continuously pressing the key  ten times until the right window flashes TL - OPEN and a mark  display at the left of the right information window. The Mark indicate the operator can setup or revise the 200 sets TOOL Libs. Continuously pressing the key  ten times will cause the 200 sets TOOL Libs to be closed and the right window flashes TL - CLOSE and the Mark  disappear. When the Mark  disappear the 200 sets TOOL Libs can not be revised.

The operations for inputting TOOL data and calling TOOL is shown as follows.

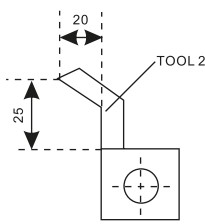
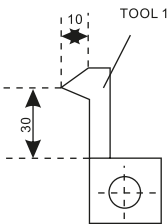

Figure 6-1

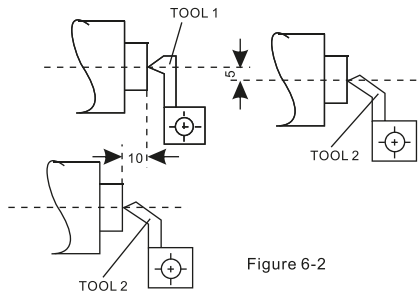
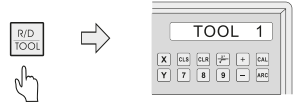

Figure 6-2

## 4. Special Functions

Step 1: In ABS state, input the data of the 200 sets TOOL Libs. To opening the 200 sets TOOL Libs by continuously pressing the key  $\frac{R}{D}$  ten time. A Mark will appear at the left window of the right info window.

Step 2: Press  $\frac{R}{D}$  to access the inputting state.



Step 3: Input TOOL 1 data:



Step 4: Input TOOL 2 data.



Step5: Press to continue to input the data of next tool. By pressing number and the key  $\frac{R}{D}$ , the operator can directly input the special tool data. Press the key  $\frac{R}{D}$  to quit.

After TOOL Libs is setup, use the TOOL Libs according to the following operations. First mount the 2nd tool.

**Step 6:** To access the using state by pressing the key  $\frac{R}{D}$

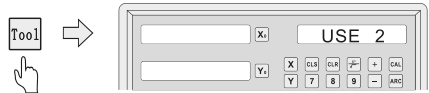

**Step 7:** Press the key  $\uparrow$   $\downarrow$  to select the current mount tool, Then press the key  $\frac{R}{D}$  to ACK and to selecting the base Tool.

**Step 8:** Select the base TOOL.

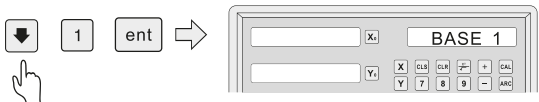

Step 9: Press the key  $\frac{R}{D}$  to quit the function.

Move worktable until X and Z axis both display zero. Now the 2nd tool can be used

**Note: when the base tool is used, the axis can be zeroed in ABS state .**

**When the others are used, the axis can only be zeroed in INC state.**

## 4. Special Functions

### 4.9.2 Taper Function:

For lathing the workpiece with taper, the taper of the workpiece can be measured in processing.

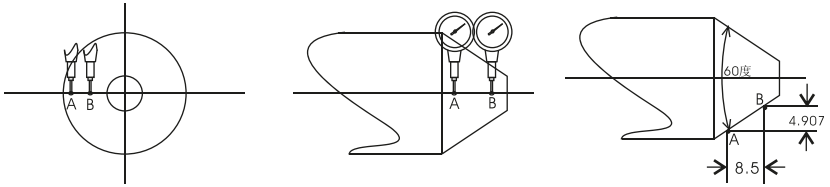

Operations:

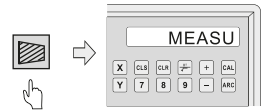

As figure, contact surface A of workpiece with lever readouts and reset the lever readouts point to zero.

**Step 1:** To access the Taper Function by pressing the key 

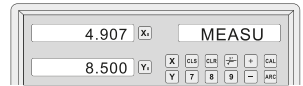

**Step 2:** Move the lever readout to the surface B until the lever readouts points to "0".



**Step 3:** Press the key  to calculate, and press the key  to quit.

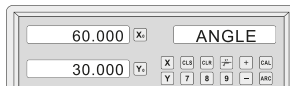

X axis : Taper  
Z axis: angle

### 4.9.3 Display of Radius / Diameter Switching

For 2 axes Lathe and 3 axes Lathe, press the key 

The display Mode of X axis is switched between Radius and Diameter

When X axis for display of Diameter, A mark  $\nabla$  will appear at the left of the right information window, but when X axis for display of diameter, the mark  $\nabla$  disappear. Only X axis has the function of the diameter / radius transformation.

### 4.9.4 Y + Z Function ( only applicable to : 3 axes Lathe)

For 3 axes Lathe, the counter of Y axis and the counter of Z axis can be added to displayed in the Z axis by pressing the key , then press the key can cancel the Y + Z function.

### 4.10 Machining Function for EDM

**4.10 .1 Description:** This function is used for the special machining of Electro Discharge Machining (EDM). When the set target value of EDM Z- axis is equal to the present value, the digital readout will output the switch signal to control EDM to stop the depth machining.

The setting of Z-axis direction the Digital Readout is shown as Fig 1, i.e. The deeper the depth is, the large the coordinate value of Z-axis displays. Since starting machining, the depth will gradually deepen and Z-axis display value will gradually increase.

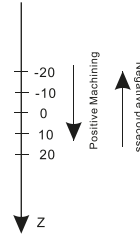

According to the set Z-axis direction, the machining direction is divided into positive and negative machining. When the electrode descends and the machining is carried out from up to down, the digital readout value will increase, which is called positive machining (Positive). The setting of this direction is the normal setting.



When the electrode ascends and the machining is carried out from down to up, the digital readout value will decrease. The machining direction is negative direction (negative), which is also called negative machining (shown as Fig.1)

The Digital Readout also features other functions, such as negative fire proof -height. Negative fireproof height function is a kind of intelligent position follow check safety protective device. In the process of machining, the electrode surface will generate the carbon accumulation phenomenon. Due to the long-time or diurnal machining without tending , when generating the carbon accumulation and nobody makes the cleaning, the electrode will slowly increase along the negative direction. Once the electrode exceeds the liquid level, it will frequently catch fire and cause losses. This function is just set to aim at this problem. When setting negative fireproof height, and the increased height of electrode exceeds the height between it and the depth of machined surface (i.e. Negative fireproof height), the digital readout display will blink for warning; at the same time, the output signal will automatically turn off EDM to eliminate the fire chance.

## 4. Special Functions

### 4.10.2 procedure :

See the following example for detailed machining.

- 1) Before machining, firstly set each parameter of DEPTH (machining depth);, ERRHIGH( negative fireproof height), machining direction(POSITIVE / NEGATIVE) ;exit mode (AUTO/STOP) and EDM Relay Output Mode.
- 2) Move the main axis electrode of Z-axis to make it contact the workpiece reference. Clear A-axis to zero or set the value.
- 3) Enter EDM machining by press the key .
- 4) X-axis will display Machining depth target value. Y-axis will display Value has been to be depth. ( The value on Y-axis is the value that the workpiece has been machined depth) Z-axis will display Self-position real time value. ( The value on Z-axis is the position value of the main axis electrode of Z-axis.)
- 5) Start machining, Z-axis display value is gradually close to the target value, and Y-axis display value is also gradually close to the target value. If at this time, the electrode is repeatedly up and down, Z-axis display value will change subsequently, but Y-axis display value will not change, which will always display the machined depth value.
- 6) When Z-axis display value is equal to the set target value, the position reaching switch will be turned off, EDM will stop machining, According to the operator setting. There are two kinds of exit modes:
  - a) Automatic Mode - it will automatically exit from EDM machining status and recover to the original state before machining;
  - b) STOP Mode - it will always stay at the machining interface after finishing machining, and you should press  to exit and back to the original state.

**Note: Relay Output pin1: COM pin2: OFF pin3: ON**

Example 1: Positive direction machining.

The DEPTH (machining Depth), ERRHIGH (Negative fireproof height), exit Mode, EDM Relay Output Mode and machining direction should be set.

Machining is shown as the model chamber as follows,

Firstly determine the machining is positive machining.

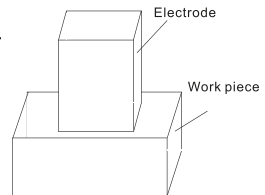
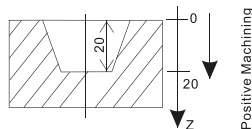

## 4. Special Functions

Step 1: Press **EDM** to enter the EDM Function.

Press **↑** to input parameters;

Press **↓** to enter EDM machining state.

(At this time, EDM is displayed at the right window)



Step 2: Input DEPTH ( machining depth).



Step 3: Input ERRHIGH ( Negative Fireproof Height )

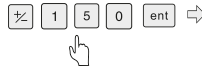

Press the key **↑**

to set the next parameter.



Step 4: Set machining direction(Positive or Negative).

Press **1** to select Positive direction.

Press **0** to select Negative direction.

Press the key **↑** to the next setting.



Step 5: Set exit Mode (AUTO Mode or STOP Mode)

press **0** to select AUTO Mode

Press **1** to select STOP Mode

Press the key **↑** to the next setting.



Step 6: Set the Output Mode (Mode 0 or Mode 1)

Press **0** to select Mode 0;

Press **1** to select Mode 1.

Mode 1: Relay Output description:

In EDM state Relay Output ON;

In the others Relay Output OFF..

Mode 0: Relay Output description:

A. Relay Output ON(PULSE) when the EDM machining is done

B. In other state, the Relay is always OFF



Step 7: Continuously press **↓** to return EDM for machining.



## 4. Special Functions

Example 2: Negative direction machining.

The DEPTH (machining Depth), B-H(backward Height), F-H(Negative fireproof height), exit Mode and machining direction should be set. Machining is shown as the model chamber as follow.

Firstly determine the machining is Negative machining.

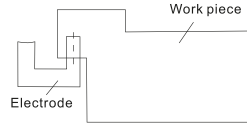
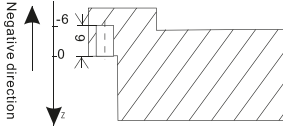

Step 1: Press **EDM** to enter the EDM Function.

Press **↑** to set parameters;

Press **↓** to enter EDM machining state.

(At this time, EDM is displayed at the right window)



Step 2: Firstly input machining depth.

Press **↑** to the next parameter setting.

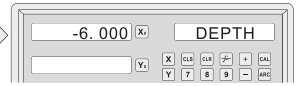

Step 3: Input the parameter ErrHIGH

( Negative fireproof height )

Press **↑** to set the next step.

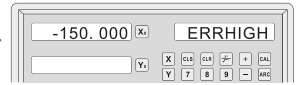
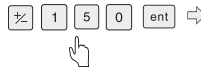

Step 4: Set machining direction(Positive or Negative).

Press **0** to select Negative direction.

Press **1** to select Positive direction.

Press the key **↑** to the next step.

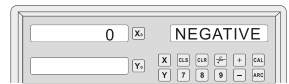

Step 5: Set exit Mode (AUTO Mode or STOP Mode)

Press **1** to select STOP Mode

Press **0** to select AUTO Mode

Press the key **↑** to the next step.



Step 6: Select Relay Output Mode

Press **0** to select MODE 0;

Press **1** to select MODE 1;

( the description about MODE 0 and MODE 1

Please refer to P47 Step 6 for detail )





## 4. Special Functions





Step 7: Continuously press the key  to enter EDM for machining.



### 4.10.3 PCD Function for EDM

PCD Function can access the EDM Function. The operator enters PCD Function to input parameters for PCD and enter PCD machining state. At every position for machining, press the key  to access the EDM Function.





When entering EDM Function, the operator can input the parameters for EDM. The operation procedure is as follows:

- 1) Set PCD parameters (the setting is the same as the common setting of PCD). After input all parameters and enter PCD machining state. The position of the first hole will be display.
- 2) Press the key  to enter EDM Function parameter (the setting method is the same as the common setting of EDM parameter); after input all parameters, continuously press  to enter EDM machining state. When the machining is done, press  to quit EDM function and enter PCD machining state.
- 3) In PCD machining state, press  for the position of the next hole, move the machine to the display value 0, then press  to access EDM function again.
- 4) Repeat the step 2 and step 3 for the following machining points.

### 4.10.4 Linear Drilling Function for EDM

Linear Drilling Function can access the EDM Function for machining. Operator can enter Linear Drilling to set parameters and enter Linear Drilling machining state. At every position for machining, press the key  to access EDM Function.

When entering EDM Function, the operator can set parameters for EDM. The operation procedure is as follows:

- 1) Set Linear Drilling Function parameters (the setting is the same as the common setting of Linear Drilling Function). After input all the parameters, then enter Linear Drilling machining state. The position of the first hole will be displayed.
- 2) Press the key  to enter EDM Function parameter (the setting method is the same as the common setting of EDM parameter); after input all parameters, continuously press  to enter EDM machining state. When the machining is done, press  to return to Linear Drilling machining state.
- 3) In Linear Drilling machining state, press  for the position of the next hole, move the machine to the display value 0, then press  to access EDM function.
- 4) Repeat the step 2 and step 3 for the following machining points.

## 5. Appendix

## 5. Appendix

### 5.1 Specifications of Digital Readout.

- 1) Supply Voltage range: AC 80 V -- 260 V; 50 -- 60 Hz
- 2) Power consumption: 15VA
- 3) Operating temperature: 0 -- 45
- 4) Storage temperature: - 30 -- 70
- 5) Relative humidity: < 90 % ( 25)
- 6) Max Coordinate number: 3
- 7) Readout allowable input signal: TTL square wave
- 8) Allowable input signal frequency: < 5 M Hz
- 9) Max resolution of digital display length: 0.1  $\mu$ m
- 10)Max resolution of digital display angle: 0.0001 / PULSE
- 11) Weight : 1.99 kg
- 12)Dimensions: 290 x 190 x 180.7(unit: mm)
- 13)Linear Scale: Pitch is 0.02mm; EPS is 5V;

Outputs 2 channels of TTL square wave

with a phase difference of 90 ( with zero position signal );

current is 50mA.

### 5.2 Installation Diagram

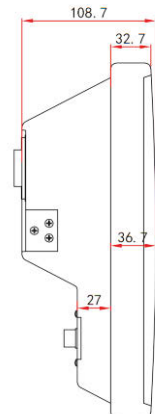
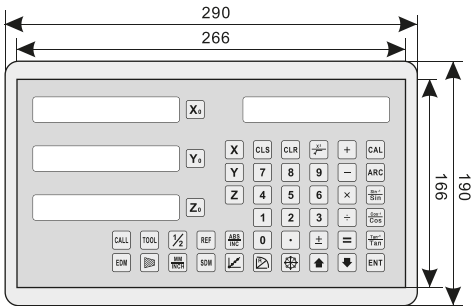

## 5. Appendix

### 5.3 Troubleshooting:

The following are the preliminary solvents for troubleshooting.

If there is still trouble, Please contact out company or agents for help.

Troubles	Possible reasons	Solvents
No display	<ol style="list-style-type: none"> <li>1. Power isn't connected</li> <li>2. Power switch is off.</li> <li>3. The range of power voltage is not right.</li> <li>4. The inner power of Linear Scale is short.</li> </ol>	<ol style="list-style-type: none"> <li>1. Check power wire and connect the power</li> <li>2. Turn on the power switch.</li> <li>3. The range of voltage is in 80--260V</li> <li>4. Unplug the connector of linear scale</li> </ol>
One axis is not counting	<ol style="list-style-type: none"> <li>1. Replace the linear scale of the other axis.</li> <li>2. DRO is in special function</li> </ol>	<ol style="list-style-type: none"> <li>1. If count is normal, the linear scale has trouble; If abnormal, the DRO readouts has trouble.</li> <li>2. Quit the special function.</li> </ol>
Linear scale is not counting	<ol style="list-style-type: none"> <li>1. Reading head is bad for using range exceeds.</li> <li>2. Aluminum chips is in reading head of linear scale.</li> <li>3. The span between the reading head and metal part of linear scale is large.</li> <li>4. The metal parts of linear scale is damage.</li> </ol>	<ol style="list-style-type: none"> <li>1. Repair the linear scale</li> <li>2. Repair the linear scale</li> <li>3. Repair the linear scale</li> <li>4. Repair the linear scale</li> </ol>
Counting is error	<ol style="list-style-type: none"> <li>1. Shell is poor grounding.</li> <li>2. Low precision of machine .</li> <li>3. Speed of machine is too rapid.</li> <li>4. Precision of linear scale is low.</li> <li>5. The resolution of DRO readouts and the linear scale is not match.</li> <li>6. The unit (mm/inch) is not match.</li> <li>7. Setting the linear compensating is not arrest.</li> <li>8. Reading head of the linear scale is damaged.</li> </ol>	<ol style="list-style-type: none"> <li>1. Shell is good grounding.</li> <li>2. Repair the machine.</li> <li>3. Reduce the speed of machine.</li> <li>4. Mount the linear scale again.</li> <li>5. Set the resolution of the DRO again.</li> <li>6. Cover the unit of display mm/inch.</li> <li>7. Reset the linear compensation.</li> <li>8. Repair the linear scale.</li> </ol>
The counting of the linear scale is not accurate	<ol style="list-style-type: none"> <li>1. The mounting of linear scale does not demand the requirement, and the prcision is not adequate.</li> <li>2. The screw is loosen.</li> <li>3. Precision of machine is low.</li> <li>4. The resolution of digital readouts and the linear scale is not match.</li> </ol>	<ol style="list-style-type: none"> <li>1. Mount the linear scale again and level it.</li> <li>2. Lock all fixing screws.</li> <li>3. Repair the machine.</li> <li>4. Reset the resolution of digital readouts.</li> </ol>
Sometimes the linear scale is not counting	<ol style="list-style-type: none"> <li>1. The small car and steel ball is separated.</li> <li>2. The glass of reading head is wearied.</li> <li>3. The glass of reading head of the linear scale has dirt.</li> <li>4. The elasticity of the steel wire is not adequate.</li> </ol>	<ol style="list-style-type: none"> <li>1. Repair the linear scale</li> <li>2. Repair the linear scale</li> <li>3. Repair the linear scale.</li> <li>4. Repair the linear scale.</li> </ol>